

Electromagnetic Friction Clutches & Brakes

Shaft Mounted Clutches – Type SL

SL SERIES POWER-ON CLUTCHES

Shaft Mounted Clutches – Type SL



SL series power-on clutches are used to couple two parallel shafts. The armature hub assembly is mounted to the same shaft as the rotor assembly. The armature hub accommodates a pulley, gear, sprocket, etc., to transmit torque to the second shaft. The field assembly is mounted on the shaft and retained by a loose-fitting pin or bracket through the anti-rotation tab.

Customer Shall Maintain:

A loose-fitting pin through the anti-rotation tab to prevent preloading the bearings.

Model SL08 through SL26

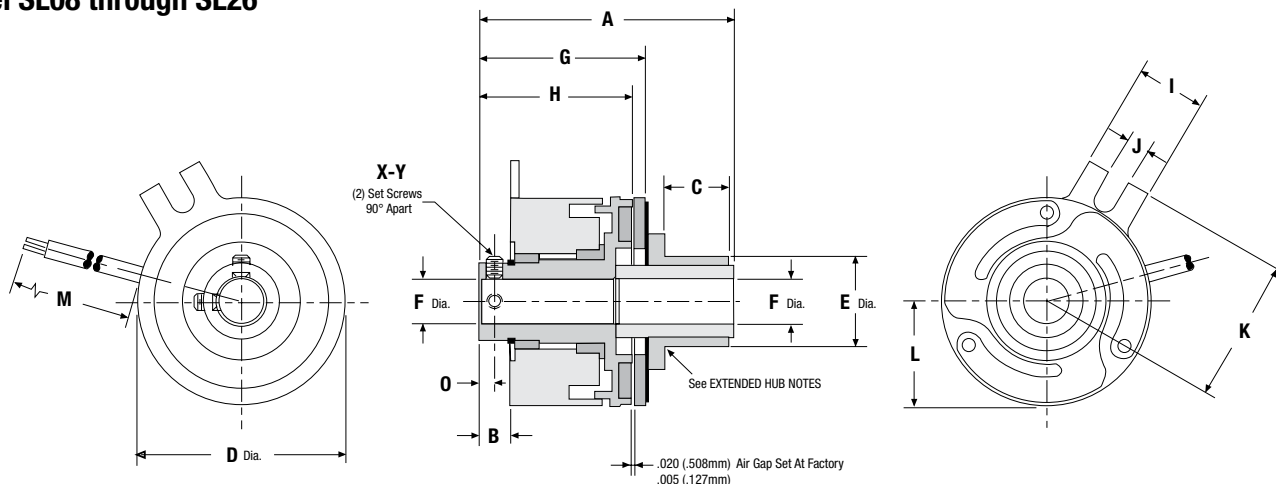

Model SL30 and SL42

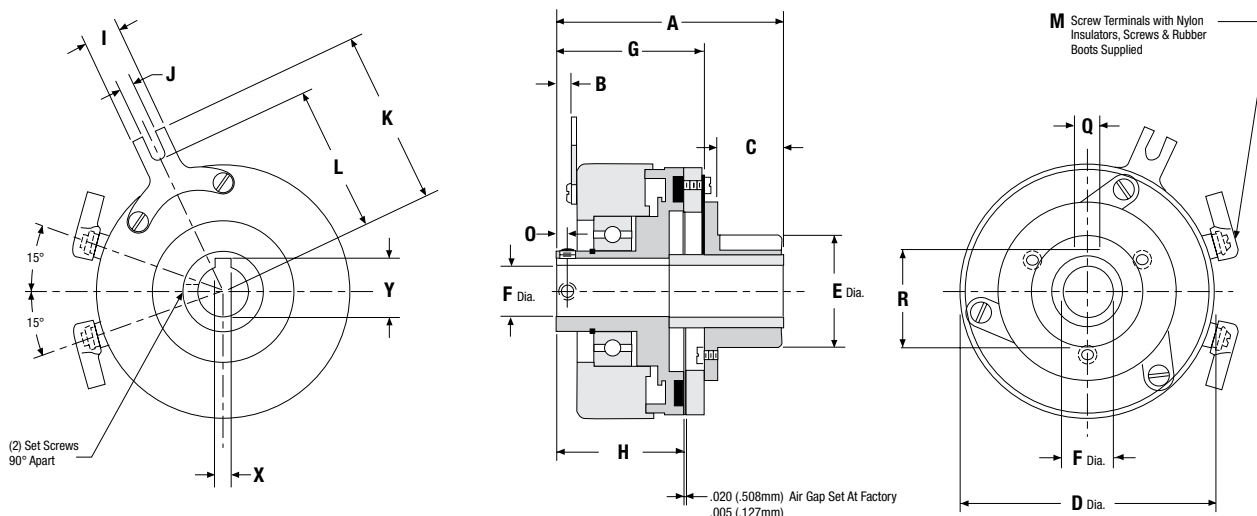

Shaft Mounted Clutches – Type SL Imperial

Mechanical

MODEL NO.	STATIC TORQUE LB. - IN.	INERTIA LB. - IN. ²		WEIGHT OZ.
		ROTOR	ARM & HUB	
SL08	2.5	.002	.0015	2.0
SL11	6	.0058	.0029	3.2
SL15	10	.060	.0031	3.8
SL17	15	.061	.036	11
SL19	25	.082	.047	12
SL22	50	.215	.079	20
SL26	80	.362	.292	28
SL30	125	.610	.561	50
SL42	250	2.50	2.30	85

Electrical

MODEL NO.	90 VDC		24 VDC		12 VDC	
	AMPS	OHMS	AMPS	OHMS	AMPS	OHMS
SL08	0.046	1977	0.117	205	0.246	48.8
SL11	0.047	1930	0.198	121	0.447	26.8
SL15	0.042	2150	0.183	132	0.38	31.6
SL17	0.066	1369	0.289	83	0.561	21.4
SL19	0.074	1213	0.294	81.6	0.574	20.9
SL22	0.079	1140	0.322	74.6	0.628	19.1
SL26	0.092	980	0.374	64.2	0.76	15.8
SL30	0.091	988	0.378	65.3	0.729	16.5
SL42	0.124	722	0.468	51.2	0.934	12.84

Lead wire is UL recognized style 1213, 1015 or 1430, 22 gage.
Insulation is .050" O.D. on 08, 11, 15 units; .064 or .095" O.D. on all other units.

Dimensions

MODEL NO.	A MAX.	B NOM.	C MAX.	D MAX.	E ± .002	F NOM.	G NOM.	H NOM.	I MAX.	J MIN.	K NOM.	L NOM.	M ± .500	O NOM.	ROTOR KEYWAY		
															BORE	KEYWAY	
																X	Y
SL08	1.37	0.191	0.41	0.903	0.507 (Knurl)	1/8 3/16 1/4	0.874	0.763	0.305	0.094	0.625	0.445	12	0.08	N.A.	SET SCREWS ONLY	
SL11	1.409	0.147	0.396	1.16	0.507 (Knurl)	3/16 1/4 5/16	0.935	0.777	0.38	0.122	0.875	0.585	12	0.087	N.A.	SET SCREWS ONLY	
SL15	1.695	0.275	0.303	1.5	0.630 (Knurl)	1/4 5/16 3/8	1.255	1.075	0.52	0.18	1.12	0.75	12	0.125	N.A.	SET SCREWS ONLY	
SL17	1.823	0.279	0.382	1.78	0.630 (Knurl)	1/4 5/16 3/8	1.316	1.06	0.505	0.184	1.325	0.975	12	0.125	N.A.	SET SCREWS ONLY	
SL19	1.948	0.279	0.465	2	0.756 (Knurl)	5/16 3/8 1/2	1.329	1.06	0.505	0.184	1.325	0.975	12	0.125	5/16 3/8 1/2	.0625-.0655 .094-.097	.347-.352 .417-.427
SL22	2.16	0.281	0.432	2.26	0.756 (Knurl)	3/8 1/2	1.578	1.423	0.442	0.17	1.515	1.16	18	0.117	3/8 1/2	.094-.097 .125-.128	.417-.427 .560-.567
SL26	2.454	0.28	0.472	2.645	0.999	3/8 1/2 5/8	1.74	1.437	0.51	0.19	1.75	1.465	18	0.154	3/8 1/2 5/8	.094-.097 .125-.128 .1885-.1905	.417-.427 .560-.567 .709-.716
SL30	2.8	0.25	0.83	3.268	1.374	1/2 5/8 3/4	1.815	1.39	0.442	0.17	2.05	1.695	SCREW TERMINALS	0.135	1/2 5/8 3/4	.125-.128 .1885-.1905 .1885-.1905	.560-.567 .709-.716 .836-.844
SL42*	3.82	0.32	1.56	4.27	1.374	1/2 5/8 3/4 7/8 1	2.05	1.625	0.645	0.19	2.5	2.312	SCREW TERMINALS	0.187	1/2 5/8 3/4 7/8* 1*	.125-.128 .1885-.1905 .1885-.1905 .1885-.1905 .251-.253	.560-.567 .709-.716 .836-.844 .962-.970 1.113-1.121

*7/8 and 1 inch bore in rotor only.

Notes:

- 08 units have set screws 120° apart
- 08 and 19 units have retaining collar
- 30 and 42 units have single ball bearing between field and rotor
- 26 units have (3)-#8-32 tapped holes on 1.375 in. B.C. in armature hub face instead of knurl
- 30 and 42 units have keyway instead of knurl (Q=.312/.314, R=1.198/1.193)
- 7/8 and 1 inch bore in rotor only for 42 unit

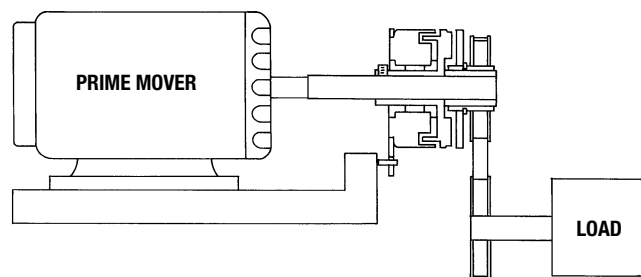

See page 4 for Ordering Information

Electromagnetic Friction Clutches & Brakes

Shaft Mounted Clutches – Type SL Metric

Mechanical

MODEL NO.	STATIC TORQUE N-m	INERTIA kg-cm ²		WEIGHT kg
		ROTOR	ARM & HUB	
SL08	.28	.006	.004	0.57
SL11	.68	.017	.008	0.91
SL15	1.13	.176	.009	.108
SL17	1.70	.179	.105	.312
SL19	2.83	.240	.138	.340
SL22	5.65	.629	.231	.567
SL26	9.04	1.062	.855	.794
SL30	14.12	1.785	1.642	1.417
SL42	28.24	7.316	6.731	2.410

Electrical

MODEL NO.	90 VDC		24 VDC		12 VDC	
	AMPS	OHMS	AMPS	OHMS	AMPS	OHMS
SL08	0.046	1977	0.117	205	0.246	48.8
SL11	0.047	1930	0.198	121	0.447	26.8
SL15	0.042	2150	0.183	132	0.38	31.6
SL17	0.066	1369	0.289	83	0.561	21.4
SL19	0.074	1213	0.294	81.6	0.574	20.9
SL22	0.079	1140	0.322	74.6	0.628	19.1
SL26	0.092	980	0.374	64.2	0.76	15.8
SL30	0.091	988	0.378	65.3	0.729	16.5
SL42	0.124	722	0.468	51.2	0.934	12.84

Lead wire is UL recognized style 1213, 1015 or 1430, 22 gage.

Insulation is 1.27 mm O.D. on 08, 11, 15 units; 1.63 or 2.41 mm O.D. on all other units.

Dimensions

MODEL NO.	A MAX.	B NOM.	C MAX.	D MAX.	E ± .051	F NOM.	G NOM.	H NOM.	I MAX.	J MIN.	K NOM.	L NOM.	M ± 12.7	O NOM.	ROTOR KEYWAY		
															BORE	KEYWAY	
																X	Y
SL08	34.798	4.851	10.414	22.936	12.878 (Knurl)	5H9	22.200	19.380	7.747	2.388	15.875	11.303	304.8	2.032	N.A.	SET SCREWS ONLY	
SL11	35.789	.734	10.058	29.464	12.582 (Knurl)	6H9 8H9	23.749	19.736	9.652	3.099	22.225	14.859	304.8	2.210	N.A.	SET SCREWS ONLY	
SL15	43.053	6.985	7.969	38.100	16.022 (Knurl)	8H9 10H9	31.877	27.305	13.208	4.572	28.448	19.050	304.8	3.175	N.A.	SET SCREWS ONLY	
SL17	46.304	7.087	9.703	45.212	16.002 (Knurl)	8H9 10H9	33.426	26.924	12.827	4.674	33.655	24.765	304.8	3.175	N.A.	SET SCREWS ONLY	
SL19	49.479	7.087	11.811	50.800	19.202 (Knurl)	10H9	33.757	26.924	12.827	4.674	33.655	24.765	304.8	3.175	10H9	2.988-3.060	11.40-11.50
SL22	54.864	7.137	10.973	57.404	19.202 (Knurl)	10H9	40.081	32.334	11.227	4.318	38.481	29.464	457.2	2.972	10H9	2.988-3.060	11.40-11.50
SL26	62.586	1.036	11.989	67.183	25.375	10H9 15H9	44.526	36.678	12.954	4.826	44.450	37.211	457.2	3.912	10H9 15H9	2.988-3.060 4.985-5.078	11.40-11.50 17.30-17.40
SL30	71.120	6.350	21.082	83.007	34.900	15H9	46.101	35.306	11.227	4.318	52.070	43.053	SCREW TERMINALS	3.429	15H9	4.985-5.078	17.30-17.40
SL42*	97.028	8.128	39.624	108.458	34.900	17H9 20H9 25H9	52.070	41.275	16.383	4.826	63.500	58.725	SCREW TERMINALS	4.750	17H9 20H9 25H9	4.985-5.078 5.985-6.078 7.982-8.098	19.30-19.40 22.80-22.90 26.30-28.50

*20 and 25 mm bore in rotor only.

Notes:

- 08 units have set screws 120° apart
- 08 and 19 units have retaining collar
- 30 and 42 units have single ball bearing between field and rotor
- 26 units have (3)-M#4 tapped holes on (34.93 mm) B.C. in armature hub face instead of knurl
- 30 and 42 units have keyway instead of knurl (Q= 7.925/7.976, R=30.429/30.302)
- 20 and 25 mm bore in rotor only for 42 unit

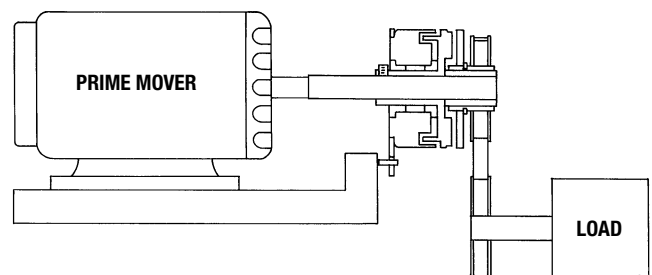

See page 4 for Ordering Information