

# Electromagnetic Friction Clutches & Brakes

## Flange Mounted Clutches – Type FL

### FL SERIES POWER-ON CLUTCHES

#### Flange Mounted Clutches – Type FL

FL series power-on clutches are used to couple two parallel shafts. The armature hub assembly is mounted to the same shaft as the rotor assembly. The armature hub accommodates a pulley, gear, sprocket, etc., to transmit torque to the second shaft. The field assembly is mounted to a bulkhead that is perpendicular to the input shaft.

#### Customer Shall Maintain:

The perpendicularity of the mounting surface with respect to the shaft not to exceed .005 inch (.127 mm) T.I.R. at a diameter equal to the bolt circle; concentricity between the clutch mounting pilot diameter and the shaft not to exceed .004 inch (.102 mm) T.I.R.



**Model FL08 through FL26**

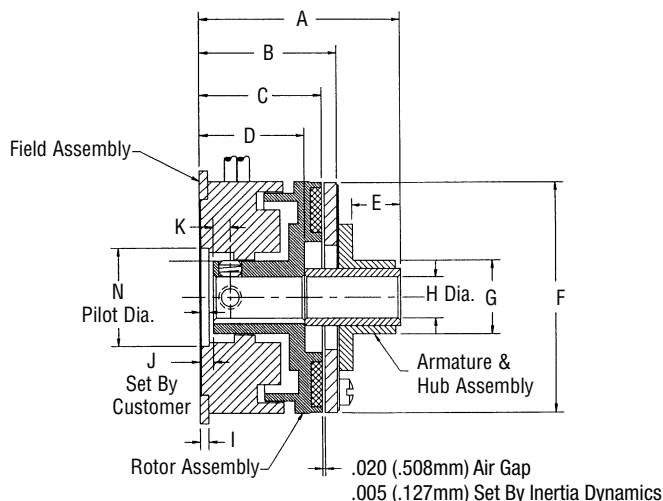
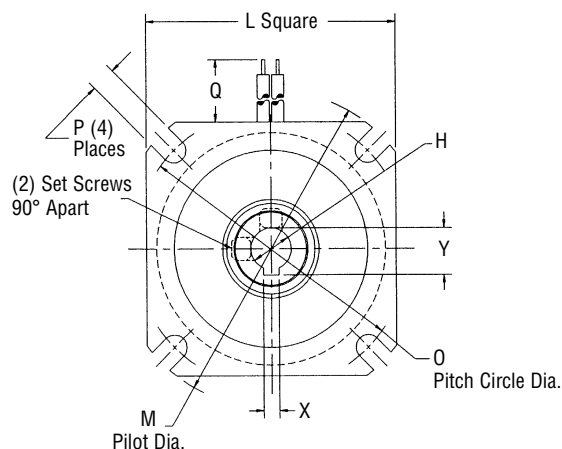

**Model FL30 and FL42**

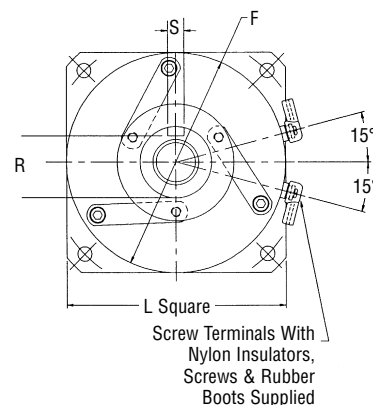
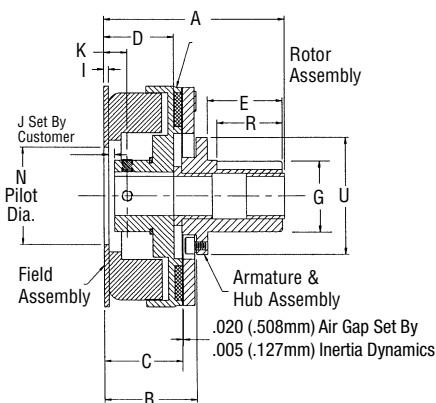
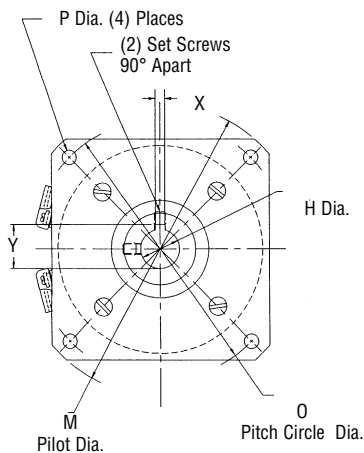

## Flange Mounted Clutches – Type FL Imperial

### Mechanical

MODEL NO.	STATIC TORQUE LB. - IN.	INERTIA LB. - IN. <sup>2</sup>		WEIGHT OZ.
		ROTOR	ARM & HUB	
FL08	2.5	.002	.0015	2.0
FL11	6	.005	.0029	3.2
FL15	10	.0054	.0031	3.8
FL17	15	.059	.036	11
FL19	25	.080	.047	12
FL22	50	.210	.079	20
FL26	80	.451	.292	28
FL30	125	.610	.561	45
FL42	250	2.50	2.30	80

### Electrical

MODEL NO.	90 VDC		24 VDC		12 VDC	
	AMPS	OHMS	AMPS	OHMS	AMPS	OHMS
FL08	.046	1977	.117	205	.246	48.8
FL11	.047	1930	.198	121	.447	26.8
FL15	.042	2150	.183	132	.380	31.6
FL17	.066	1369	.289	83	.561	21.4
FL19	.074	1213	.322	74.4	.574	20.9
FL22	.079	1140	.322	74.6	.628	19.1
FL26	.092	980	.374	64.2	.760	15.8
FL30	.091	988	.378	65.3	.729	16.5
FL42	.124	722	.468	51.2	.934	12.84

Lead wire is UL recognized style 1213, 1015 or 1430, 22 gage.

Insulation is .050" O.D. on 08, 11, 15 units; .064" or .095" O.D. on all other units.

### Dimensions

MODEL NO.	A MAX.	B NOM.	C NOM.	D NOM.	E MAX.	F MAX.	G ±.002	H NOM.	I MAX.	J ±.005	K NOM.	L MAX.	M ±.001	N ±.001	O NOM.	P MIN.	Q ±.500	ROTOR KEYWAY			R MIN.	S ±.002
																		BORE	KEYWAY			
																			X	Y		
FL08	1.203	.715	.641	.582	.410	.905	.507	1/8 3/16 1/4	.034	.020	.188	.980	1.1995	N.A.	1.030	.094	12.00	N.A.	ONE ROLL PIN PILOT HOLE		-	-
FL11	1.253	.774	.691	.616	.396	1.160	.505	3/16 1/4 5/16	.048	.020	.188	1.230	1.498	N.A.	1.312	.123	12.00	N.A.	ONE ROLL PIN PILOT HOLE		-	-
FL15	1.420	.975	.870	.805	.303	1.500	.630	1/4 5/16 3/8	.063	.100	.130	1.567	1.999	N.A.	1.750	.156	12.00	N.A.	ONE ROLL PIN PILOT HOLE		-	-
FL17	1.568	1.053	.925	.800	.382	1.789	.630	1/4 5/16 3/8	.064	.100	.130	1.943	2.436	.751	2.125	.186	12.00	1/4 5/16 3/8	.0625 - .0655 .0625 - .0655 .094 - .097	.285 - .290 .347 - .352 .417 - .427	-	-
FL19	1.675	1.050	.910	.790	.470	2.000	.756	5/16 3/8 1/2	.062	.100	.130	1.943	2.436	.751	2.125	.186	12.00	5/16 3/8 1/2	.0625 - .0655 .094 - .097 ROLL PIN HOLE	.347 - .352 .417 - .427	-	-
FL22	1.928	1.328	1.173	1.023	.432	2.260	.756	3/8 1/2	.096	.100	.188	2.322	2.873	1.001	2.500	.160	18.00	3/8 1/2	.094 - .097 .125 - .128	.417 - .427 .560 - .567	-	-
FL26	2.173	1.458	1.300	1.150	.472	2.645	.999	3/8 1/2 5/8	.064	.375	.172	2.630	3.499	1.062	3.125	.182	18.00	3/8 1/2 5/8	.094 - .097 .125 - .128 .1885 - .1905	.417 - .427 .560 - .567 .709 - .716	-	-
FL30	2.575	1.580	1.310	1.160	.830	3.268	1.374	1/2 5/8 3/4	.097	.147	.310	3.200	4.186	1.751	3.750	.182	SCREW TERMINALS	1/2 5/8 3/4	.125 - .128 .1885 - .1905 .1885 - .1905	.560 - .567 .709 - .716 .836 - .844	1.198 1.193	.312 .314
FL42*	3.540	1.760	1.490	1.345	1.550	4.255	1.374	1/2 5/8 3/4 7/8 1	.097	.190	.250	4.255	5.624	1.875	5.000	.276	SCREW TERMINALS	1/2 5/8 3/4 7/8* 1*	.125 - .128 .1885 - .1905 .1885 - .1905 .1885 - .1905 .251 - .253	.560 - .567 .709 - .716 .836 - .844 .962 - .970 1.113 - 1.121	1.198 1.193	.312 .314

\*7/8 and 1 inch bore in rotor only.

### Notes:

- 08, 11 and 15 units have one roll pin pilot hole in rotor – no set screws.
- 26 units have (3) – #8–32 tapped holes on 1.375 in. B.C. in armature hub face instead of knurl.
- 30 and 42 units have keyway instead of knurl.
- 7/8 and 1 inch bore in rotor only for 42 unit.

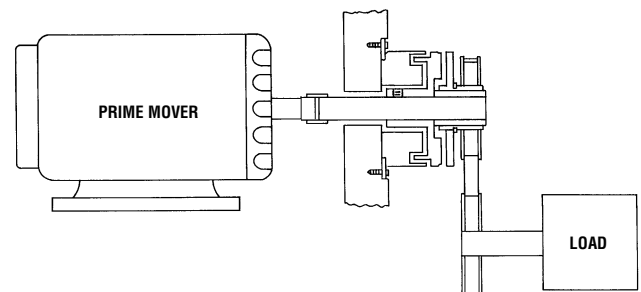

See page 4 for Ordering Information

# Electromagnetic Friction Clutches & Brakes

## Flange Mounted Clutches – Type FL Metric

### Mechanical

MODEL NO.	STATIC TORQUE N-m	INERTIA kg-cm <sup>2</sup>		WEIGHT kg
		ROTOR	ARM & HUB	
FL08	.28	.006	.004	.057
FL11	.68	.015	.008	.091
FL15	1.13	.016	.009	.108
FL17	1.70	.173	.105	.312
FL19	2.83	.234	.138	.340
FL22	5.65	.615	.231	.567
FL26	9.04	1.320	.855	.794
FL30	14.12	1.785	1.64	1.28
FL42	28.24	7.316	6.73	2.27

### Electrical

MODEL NO.	90 VDC		24 VDC		12 VDC	
	AMPS	OHMS	AMPS	OHMS	AMPS	OHMS
FL08	.046	1977	.117	205	.246	48.8
FL11	.047	1930	.198	121	.447	26.8
FL15	.042	2150	.183	132	.380	31.6
FL17	.066	1369	.289	83	.561	21.4
FL19	.074	1213	.322	74.4	.574	20.9
FL22	.079	1140	.322	74.6	.628	19.1
FL26	.092	980	.374	64.2	.760	15.8
FL30	.091	988	.378	65.3	.729	16.5
FL42	.124	722	.468	51.2	.934	12.84

Lead wire is UL recognized style 1213, 1015 or 1430, 22 gage.

Insulation is 1.27 mm O.D. on 08, 11, 15 units; .163 mm or 2.41 mm O.D. on all other units.

### Dimensions

MODEL NO.	A MAX.	B NOM.	C NOM.	D NOM.	E MAX.	F MAX.	G ±.051	H NOM.	I MAX.	J ±.127	K ±.127	L MAX.	M ±.025	N ±.025	O NOM.	P MIN.	Q ± 12.7	ROTOR KEYWAY		R MIN.	S ±.051	
																		BORE	KEYWAY			
																			X			Y
FL08	30.556	17.551	16.281	14.783	10.414	22.987	12.878	5H9	0.864	0.508	4.775	24.892	30.467	N.A.	26.162	2.388	304.800	N.A.	ONE ROLL PIN PILOT HOLE	-	-	
FL11	31.826	19.660	17.551	15.646	10.058	29.464	12.827	6H9 8H9	.219	0.508	4.775	31.242	38.049	N.A.	33.325	3.124	304.800	N.A.	ONE ROLL PIN PILOT HOLE	-	-	
FL15	36.068	24.765	22.098	20.447	7.696	38.100	16.002	8H9 10H9	1.600	2.540	3.302	39.802	50.775	N.A.	44.450	3.962	304.800	N.A.	ONE ROLL PIN PILOT HOLE	-	-	
FL17	39.827	26.746	23.495	20.320	9.703	45.441	16.002	8H9	1.626	2.540	3.302	49.352	61.879	19.050	53.975	4.724	304.800	8H9	1.988-2.060 9.00-9.10	-	-	
FL19	42.545	26.670	23.114	20.066	11.938	50.800	19.202	10H9	1.575	2.540	3.302	49.352	61.874	19.050	53.975	4.724	308.800	10H9	2.988-3.060 11.40-11.50	-	-	
FL22	48.971	33.731	29.794	25.984	10.973	57.404	19.202	10H9	2.438	2.540	4.775	58.979	72.974	25.425	63.500	4.064	457.200	10H9	2.988-3.060 11.40-11.50	-	-	
FL26	55.194	37.033	33.020	29.210	11.989	67.183	25.375	10H9 15H9	1.626	9.525	4.369	66.802	88.875	26.975	79.375	4.623	457.200	10H9 15H9	2.988-3.060 4.985-5.078 17.30-17.40	-	-	
FL30	65.405	40.132	33.274	29.464	26.082	83.007	34.900	15H9	2.464	3.734	7.874	81.280	106.324	44.475	95.250	4.623	SCREW TERMINALS	15H9	4.985-5.078 17.30-17.40	30.429 30.302	7.925 7.976	
FL42*	89.916	44.704	37.846	34.163	39.370	108.458	34.900	17HP 20H9 25H9	2.464	4.826	6.350	108.077	142.850	47.625	127.000	7.010	SCREW TERMINALS	17H9 20H9 25H9	4.985-5.078 5.985-6.078 7.982-8.098 19.30-19.40 22.80-22.90 28.30-28.50	30.429 30.302	7.925 7.976	

\*20 and 25 mm bore in rotor only.

### Notes:

- 08, 11 and 15 units have one roll pin pilot hole in rotor – no set screws.
- 26 units have (3) – #8–32 tapped holes on 34.925 mm B.C. in armature hub face instead of knurl.
- 30 and 42 units have keyway instead of knurl.
- 20 and 25 mm metric bore in rotor only for 42 unit.

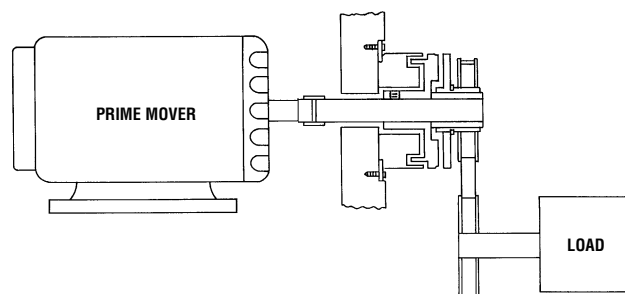

See page 4 for Ordering Information