

TXM24C

Integrated Step-Servo Motor Hardware Manual



Rev. D
920-0088
6/15/2015



Sold & Serviced By:
 **ELECTROMATE**

Toll Free Phone (877) SERV098
Toll Free Fax (877) SERV099
www.electromate.com
sales@electromate.com

Contents

1	Introduction	3
1.1	Features.....	3
1.2	Block Diagram	4
1.3	Safety Instructions	5
2	Getting Started	6
2.1	Installing Software	6
2.2	Mounting the Hardware	6
2.3	Choosing a Power Supply	7
2.3.1	Voltage	7
2.3.2	Regeneration Clamp	7
2.3.3	Current	8
3	Installation/Connections	11
3.1	Connecting the Power Supply	11
3.2	Connecting the TXM24C Communications.....	12
3.2.1	Node ID	13
3.2.2	Setting the Bitrate.....	13
3.3	Inputs and Outputs	14
3.3.1	Connector Pin Diagram	14
3.3.2	X1 & X2 Inputs	15
3.3.3	X3, X4, X5 Input.....	16
3.3.4	What is COM?	16
3.3.5	Programmable Output	18
4	Troubleshooting	19
5	Reference Materials	20
5.1	Torque-Speed Curves.....	20
5.2	Mechanical Outlines	21
5.3	Technical Specifications.....	22
5.4	Accessories.....	23
6	Contacting Applied Motion Products.....	23

1 Introduction

Thank you for selecting the Applied Motion Products TXM24C Integrated Motor. The TXM line of integrated step-servo motors combines servo technology with an integrated motor to create a product with exceptional feature and broad capability. We hope our commitment to performance, quality and economy will result in a successful motion control project.



1.1 Features

- Programmable, Digital servo driver and motor in an integrated package
- Operates from a 12 to 70 volts DC power supply
- Modes of Operation:
 - CANopen(compliant CiA 402)
 - Profile Torque
 - Profile Velocity
 - Profile Position
 - Homing
 - Q Programing
 - Execute stored Q programs via Applied Motion Products specific CANopen objects
- Communications:
 - CANopen & RS-232
- 5000 line (20,000 counts/rev) encoder feedback
- Available torque:
 - TXM24C-1CG: Up to 0.82N•m Continuous (1.03 N•m Boost)
 - TXM24C-3CG: Up to 2.4N•m Continuous (3.0 N•m Boost)
- I/O:
 - 5 optically isolated digital inputs, with adjustable bandwidth digital noise rejection filter, 5 to 24 volts
 - 3 optically isolated digital output, 30V/100 mA max.
- Technological advances:
 - Full servo control, Closed loop
 - Efficient, Accurate, Fast, Smooth
 - Intelligent, Compact
- IP65 protected with four M12 connectors

Model	Communications	
	RS-232	CANopen
TXM24C-3CG, TXM24C-3CG	✓	✓

1.2 Block Diagram

TXM24C
Block Diagram

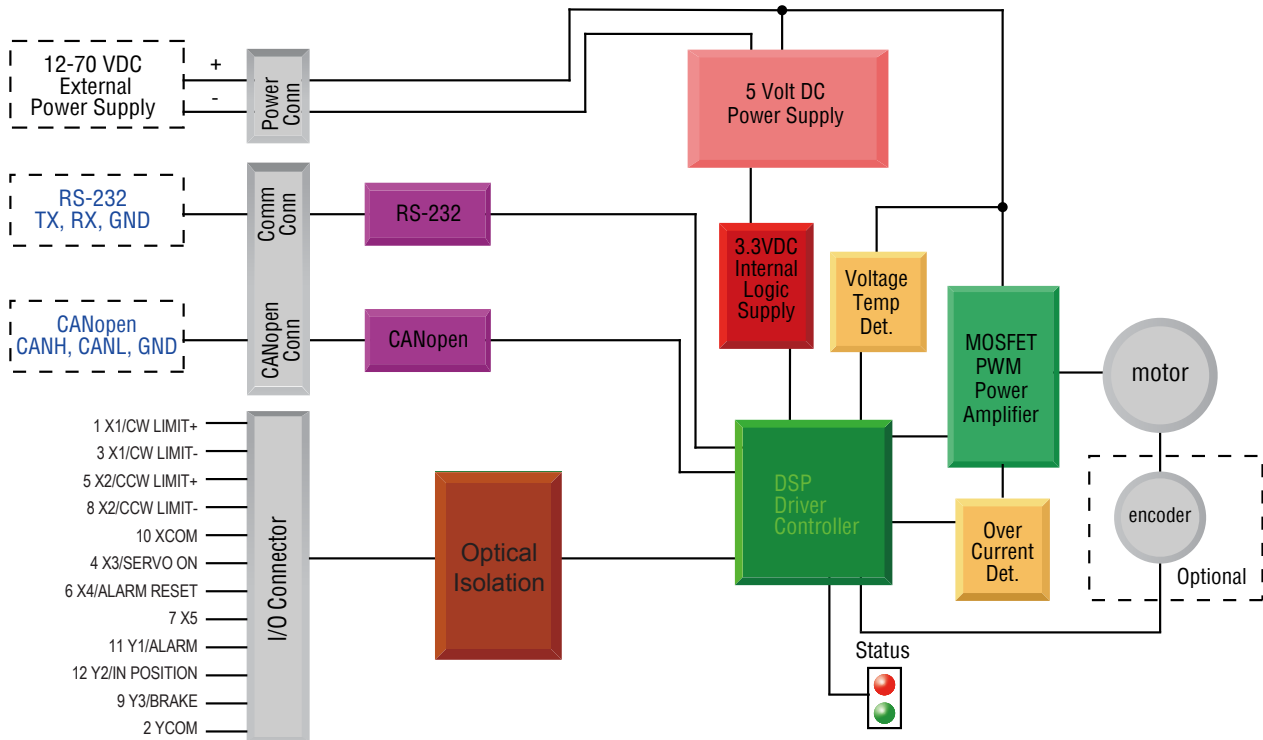

I/O Configurations

X1 (5 to 24 Volts) : CW Limit : General Purpose	X4 (5 to 24 Volts) : Alarm Reset : General Purpose	Y1 (30V, 100mA) : Alarm Output : General Purpose
X2 (5 to 24 Volts) : CCW Limit : General Purpose	X5 (5 to 24 Volts) : General Purpose	Y2 (30V, 100mA) : In Position : General Purpose
X3 (5 to 24 Volts) : Servo On : General Purpose		Y3 (30V, 100mA) : Brake Output : General Purpose

1.3 Safety Instructions

Only qualified personnel should transport, assemble, install, operate, or maintain this equipment. Properly qualified personnel are persons who are familiar with the transport, assembly, installation, operation, and maintenance of motors, and who meet the appropriate qualifications for their jobs.

To minimize the risk of potential safety problems, all applicable local and national codes regulating the installation and operation of equipment should be followed. These codes may vary from area to area and it is the responsibility of the operating personnel to determine which codes should be followed, and to verify that the equipment, installation, and operation are in compliance with the latest revision of these codes.

Equipment damage or serious injury to personnel can result from the failure to follow all applicable codes and standards. Applied Motion Products does not guarantee the products described in this publication are suitable for a particular application, nor do they assume any responsibility for product design, installation, or operation.

- Read all available documentation before assembly and operation. Incorrect handling of the products referenced in this manual can result in injury and damage to persons and machinery. All technical information concerning the installation requirements must be strictly adhered to.
- It is vital to ensure that all system components are connected to earth ground. Electrical safety is impossible without a low-resistance earth connection.
- This product contains electrostatically sensitive components that can be damaged by incorrect handling. Follow qualified anti-static procedures before touching the product.
- During operation keep all covers and cabinet doors shut to avoid any hazards that could possibly cause severe damage to the product or personal health.
- During operation, the product may have components that are live or have hot surfaces.
- Never plug in or unplug the Integrated Motor while the system is live. The possibility of electric arcing can cause damage.

Be alert to the potential for personal injury. Follow recommended precautions and safe operating practices emphasized with alert symbols. Safety notices in this manual provide important information. Read and be familiar with these instructions before attempting installation, operation, or maintenance. The purpose of this section is to alert users to the possible safety hazards associated with this equipment and the precautions necessary to reduce the risk of personal injury and damage to equipment. Failure to observe these precautions could result in serious bodily injury, damage to the equipment, or operational difficulty.

2 Getting Started

The following items are needed:

- a 12 - 70 volt DC power supply, see the section below entitled “Choosing a Power Supply” for help in choosing the right one
- a PC running Microsoft Windows XP, Vista, or Windows 7 or 8

2.1 Installing Software

Before utilizing the TXM24C Integrated Motor and Step-Servo Quick Tuner Software in an application, the following steps are necessary:

- Download and install the Step-Servo Quick Tuner software from Applied Motion Products website.
- Connect the drive to the PC using the RS-232 programming cable.
- Connect the drive to the power supply. See instructions below.
- Launch the software by clicking Start...Programs...Applied Motion Products...Step-Servo Quick Tuner.
- Apply power to the drive.
- The software will recognize the drive and display the model and firmware version. At this point, it is ready for use.

2.2 Mounting the Hardware

As with any step motor, the TXM24C must be mounted so as to provide maximum heat sinking and airflow. Keep enough space around the Integrated Motor to allow for airflow.



- Never use the drive where there is no airflow or where other devices cause the surrounding air to be more than 40°C (104°F).
- Never put the drive where it can get wet.
- Never use the drive where metal or other electrically conductive particles can infiltrate the drive.
- Always provide airflow around the drive.

2.3 Choosing a Power Supply

The main considerations when choosing a power supply are the voltage and current requirements for the application.

2.3.1 Voltage

The TXM24C is designed to give optimum performance between 24 and 48 Volts DC. Choosing the voltage depends on the performance needed and motor/drive heating that is acceptable and/or does not cause a drive over-temperature. Higher voltages will give higher speed performance but will cause the TXM24C to produce higher temperatures. Using power supplies with voltage outputs that are near the drive maximum may significantly reduce the operational duty-cycle.

The extended range of operation can be as low as 10 VDC minimum to as high as 75 VDC maximum. When operating below 18 VDC, the power supply input may require larger capacitance to prevent under-voltage and internal-supply alarms. Current spikes may make supply readings erratic. The supply input cannot go below 10 VDC for reliable operation. Absolute minimum power supply input is 10 VDC. If the Input supply drops below 10 VDC the low voltage alarm will be triggered. This will not fault the drive.

Absolute maximum power supply input is 75 VDC at which point an over-voltage alarm and fault will occur. When using a power supply that is regulated and is near the drive maximum voltage of 75 VDC, a voltage clamp may be required to prevent over-voltage when regeneration occurs. When using an unregulated power supply, make sure the no-load voltage of the supply does not exceed the drive's maximum input voltage of 75 VDC.

2.3.2 Regeneration Clamp

If a regulated power supply is being used, there may be a problem with regeneration. When a load decelerates rapidly from a high speed, some of the kinetic energy of the load is transferred back to the power supply, possibly tripping the over-voltage protection of a regulated power supply, causing it to shut down. This problem can be solved with the use of an Applied Motion Products RC880 Regeneration Clamp. It is recommended that an RC880 initially be installed in an application. If the "regen" LED on the RC880 never flashes, the clamp is not necessary.

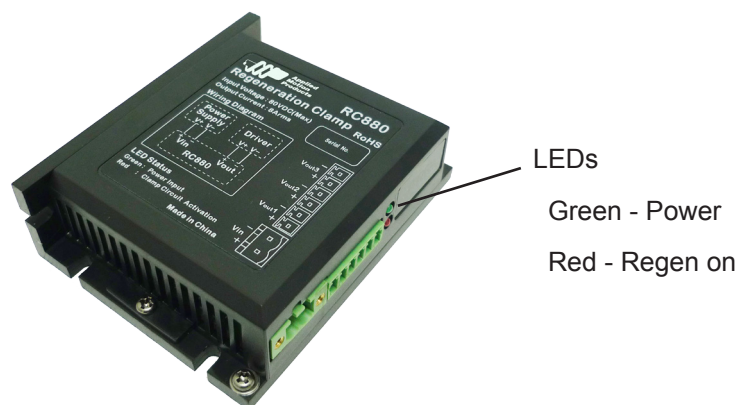

RC880 Regen Clamp

2.3.3 Current

The maximum supply currents required by the TXM24C are shown in the charts below at different power supply voltage inputs. The TXM24C power supply current is lower than the winding currents because it uses switching amplifiers to convert a high voltage and low current into lower voltage and higher current. The more the power supply voltage exceeds the motor voltage, the less current will be required from the power supply.

It is important to note that the current draw is significantly different at higher speeds depending on the torque load to the motor. Estimating how much current is necessary may require a good analysis of the load the motor will encounter.

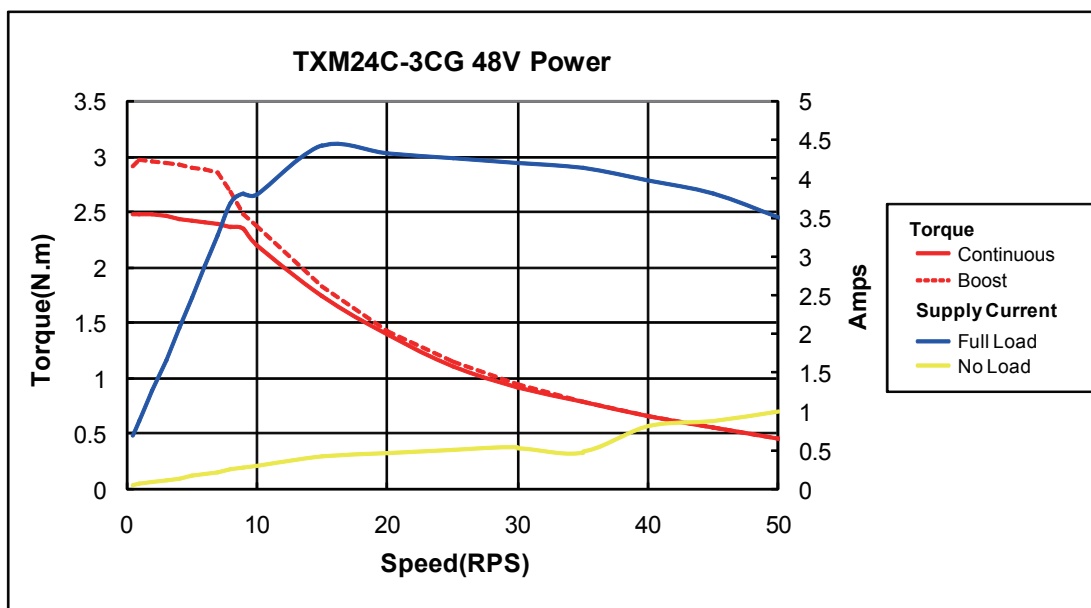
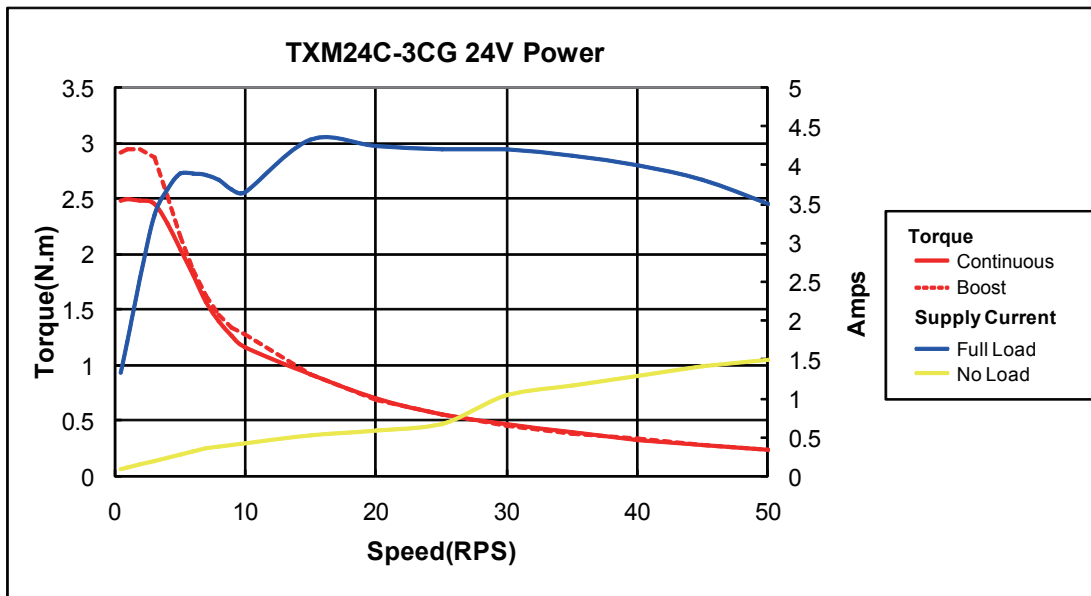

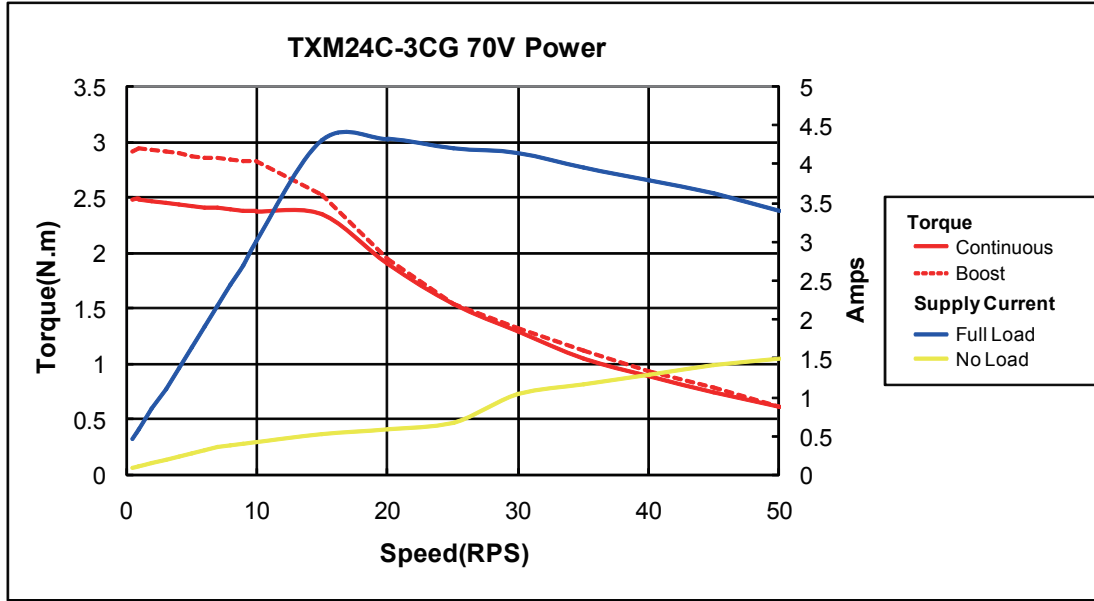

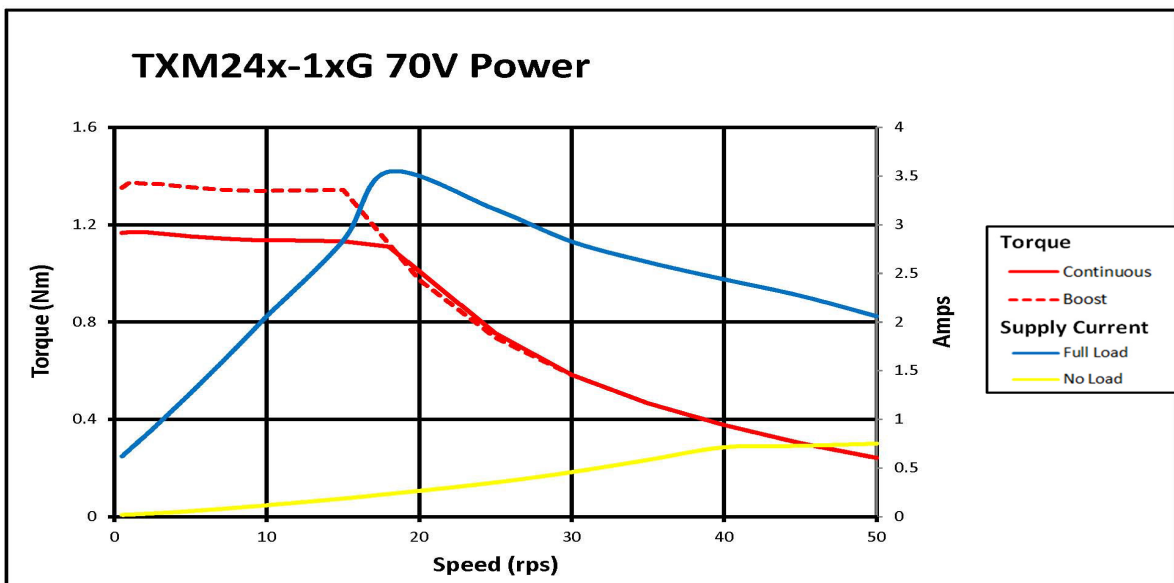
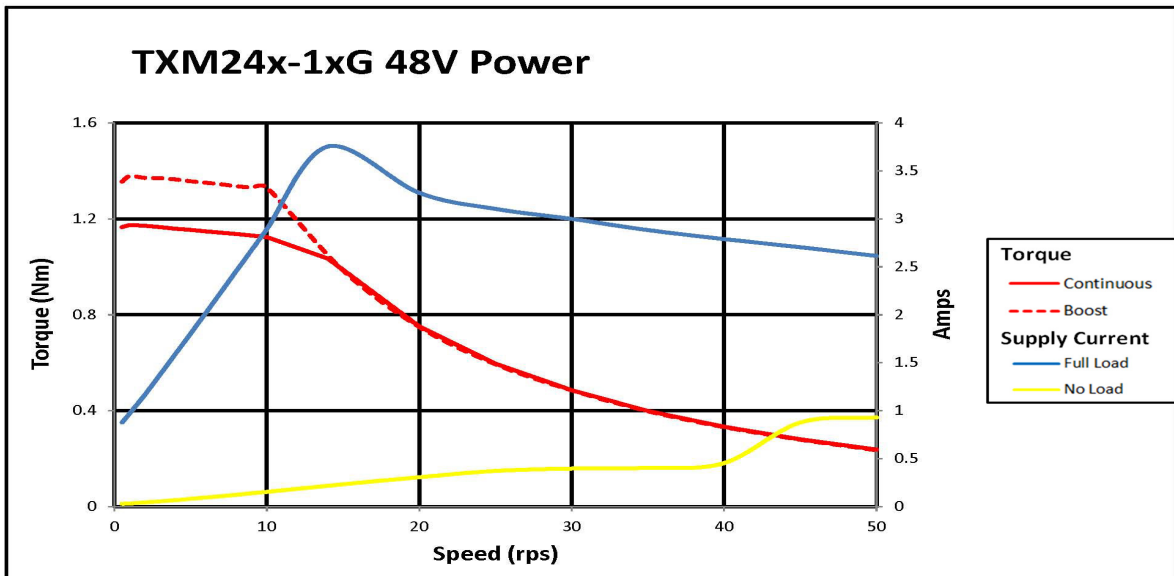
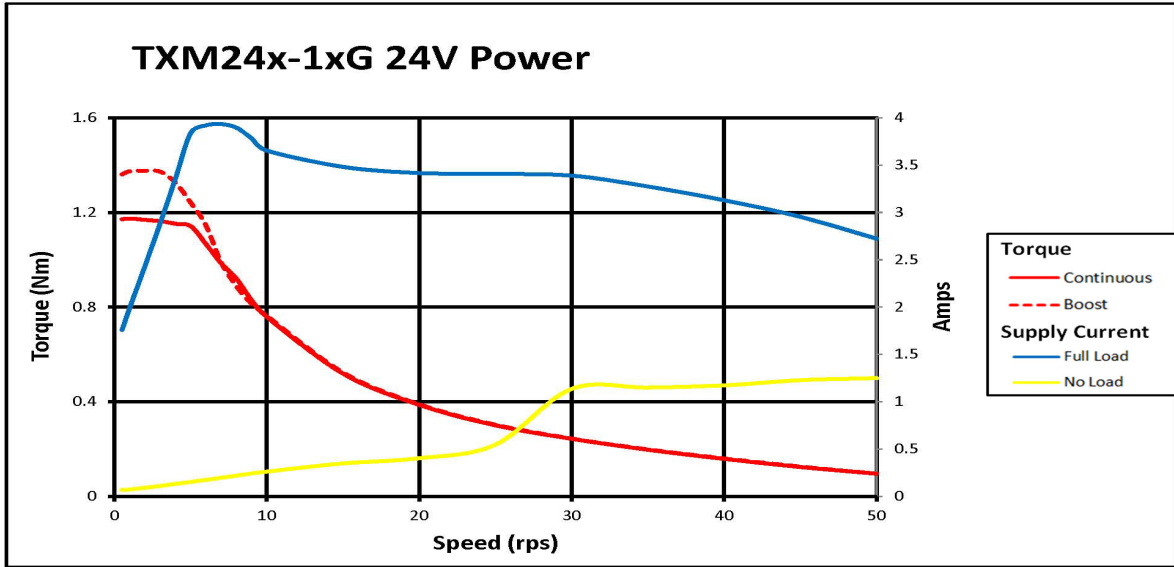

3 Installation/Connections

To meeting the IP65 protection, a suitable mating connector should be chosen. We recommend vendor Phoenix Contact that offers mating cable with perfect match to our motor.

You can also check information of recommended mating cable from Phoenix in Accessories section.

3.1 Connecting the Power Supply

Use 16 to 20-gauge wire if you want to build cable by yourself. TXM24C contains an internal fuse connected to the “+” terminal that is not user replaceable. If a user serviceable fuse is desired, install a 6.3 amp fast acting fuse in line with the “+” power supply lead.



Be careful not to reverse the wires. Reversing the connection may open the internal fuse on the drive and void the warranty.

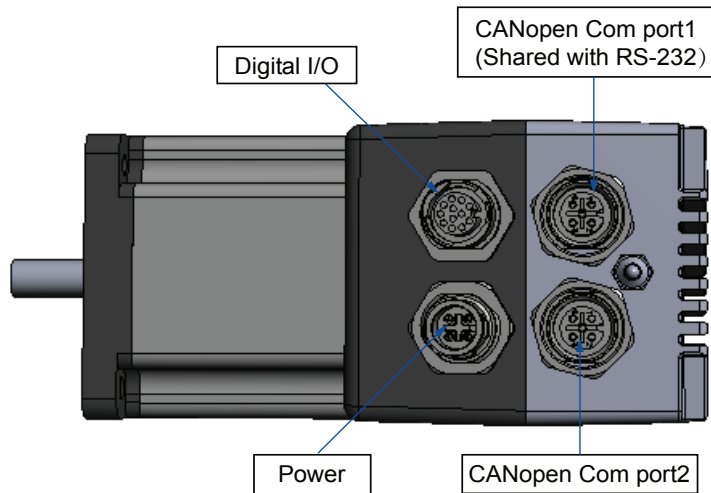

Power

Signal	Color of mating cable Phoenix P/N 1431678	Pin no.
V+	BN\BU	1\3
V-	WH\BK	2\4

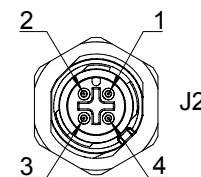

View of motor side connector

3.2 Connecting the TXM24C Communications

The communications interface for the TXM24C is two standard 5-pin M12 connectors. The TXM24C is configured by Step-Servo Quick Tuner with RS-232 serial link, and then may be deployed on a distributed CANopen network. The RS-232 interface is used for configuration, tuning, node ID setting and Q program downloading.

Communication port

Signal	Color of mating cable Applied Motion PN 3004-288-5M	Pin no.
RS-232_TXD	BN	1
RS-232_RXD	WH	2
GND	BU	3
CAN_H	BK	4
CAN_L	GN/YE	5

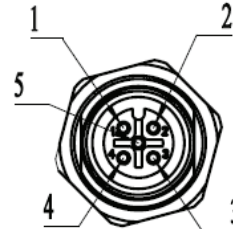

View of motor side connector

Note: If the PC does not have an RS-232 serial port, a USB Serial Converter will be needed.

You can contact Applied Motion Products to buy a USB to RS-232 converter.

The RS-232 circuitry does not have any extra electrical “hardening” and care should be taken when connecting to the RS-232 port as hot plugging could result in circuit failure.

The CANopen network should be connected in a daisy-chain fashion, with a 120 ohm terminating resistor at each end of network.

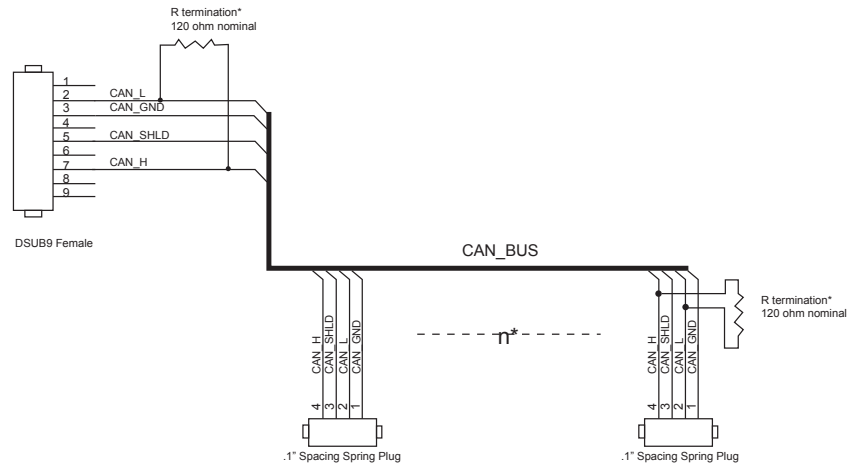

R termination:
Network must be terminated at each end with a 120 ohm resistor.

n:
Cable may be made with up to 127 drive connectors. Termination is only required at each end.

3.2.1 Node ID

Each node ID on a CANopen network must have a unique Node ID. The Node ID is configured by using Step-Servo Quick Tuner software. CANopen Node IDs are seven bits long, with a range of 1 - 127, or 0x01 - 0x7F in hexadecimal notation. Node ID 0x00 is reserved in accordance with the CiA301 specification.

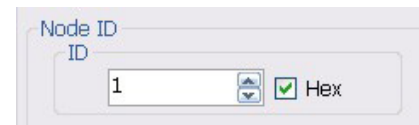

3.2.2 Setting the Bitrate

The CANopen network bitrate is set by the Step-Servo Quick Tuner software. The bit rate must be the same for all nodes on the CANopen network. Any changes to the bit rate require either a power cycle or a CANopen reset command to take effect.

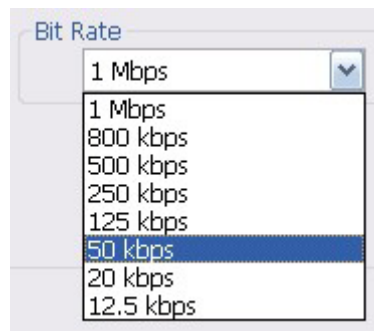

3.3 Inputs and Outputs

The TXM24C has five optically isolated inputs that use 5 to 24V logic.

3.3.1 Connector Pin Diagram

I/O

Signal	Color of mating cable	Pin no.
X1+	BN	1
YCOM	BU	2
X1-	WH	3
X3	GN	4
X2+	PK	5
X4	YE	6
X5	BK	7
X2-	GY	8
Y3	RD	9
XCOM	VT	10
Y1	GYPK	11
Y2	RDBU	12

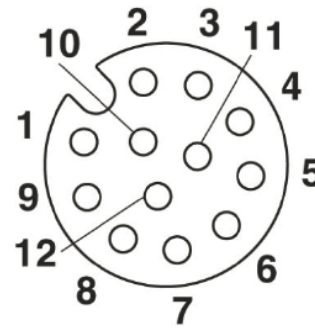

View of motor side connector

3.3.2 X1 & X2 Inputs

X1 and X2 digital inputs are designed operation between 5 and 24 volts. The diagrams below show how to connect them to various commonly used devices like sensors, switches, relays, PLCs, etc.

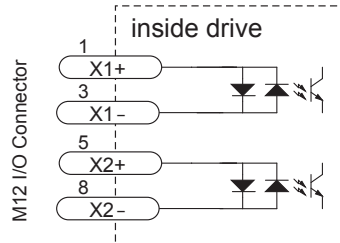

Note: If current is flowing into or out of an input, the logic state of that input is low or closed. If no current is flowing, or the input is not connected, the logic state is high or open.

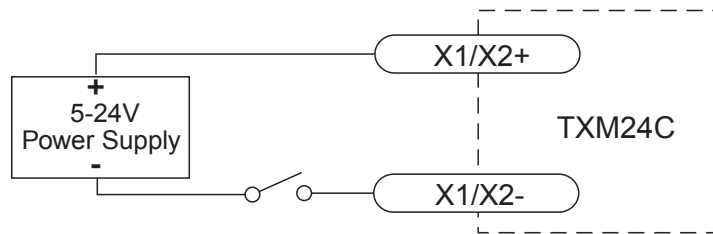

Connecting a Mechanical Switch to Low Speed Differential Inputs

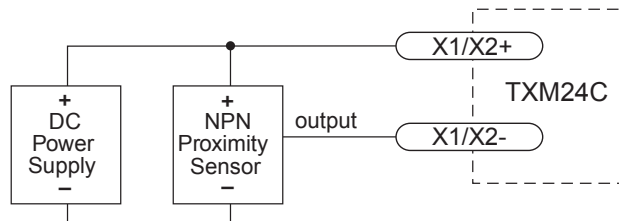

Connecting an NPN Proximity Sensor to Low Speed Differential Inputs

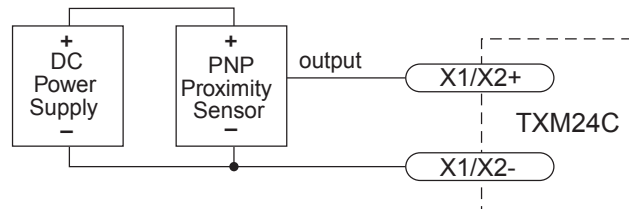

Connecting a PNP Proximity Sensor to Low Speed Differential Inputs

3.3.3 X3, X4, X5 Input

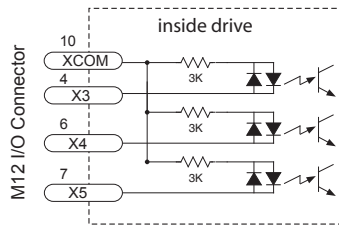

The X3, X4, X5 digital input is designed for low speed digital input operation between 5 and 24 volts. The diagrams below show how to connect them to various commonly used devices like sensors, switches, relays, PLCs, etc.

Note: If current is flowing into or out of an input, the logic state of that input is low or closed. If no current is flowing, or the input is not connected, the logic state is high or open.

3.3.4 What is COM?

“Common” is an electronics term for an electrical connection to a common voltage. Sometimes “common” means the same thing as “ground”, but not always. In the case of the TXM24C drives, if you are using sourcing (PNP) input signals, then you will want to connect COM to ground (power supply -). If you are using sinking (NPN) signals, then COM must connect to power supply +.

Note: If current is flowing into or out of an input, the logic state of that input is low or closed. If no current is flowing, or the input is not connected, the logic state is high or open.

The diagrams on the following pages show how to connect the inputs to various commonly used devices.

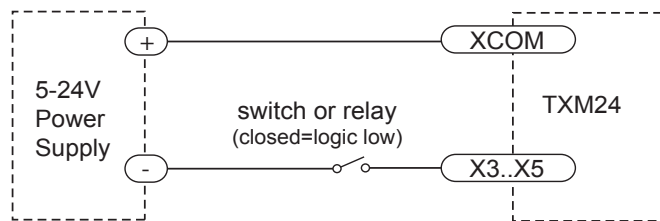

Connecting an Input to a Switch or Relay

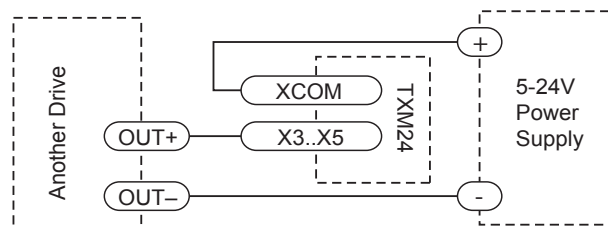

Connecting another drive to the TXM24
(When output closes, input goes low).

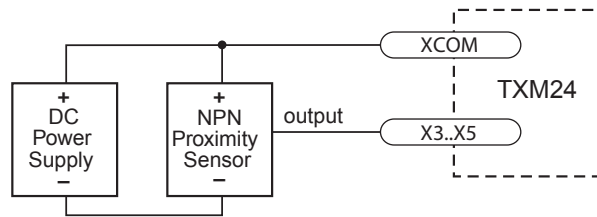

Connecting an NPN Proximity Sensor to Low Speed Differential Inputs
(when prox sensor activates, input goes low)

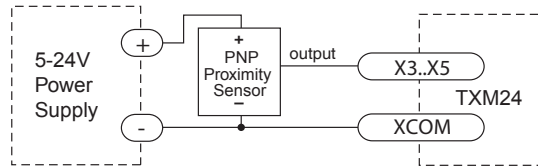

Connecting a PNP Type Proximity Sensor to an input
(When prox sensor activates, input goes high)

3.3.5 Programmable Output

The TXM24C drives feature three optically isolated digital output (Y1,Y2,Y3). This output can be set to automatically control a motor brake, to signal a fault condition, to indicate when the motor is in position or to provide an output frequency proportional to motor speed (tach signal). Or the output can be turned on and off by program instructions like Set Output (SO). The output can be used to drive LEDs, relays and the inputs of other electronic devices like PLCs and counters. Y1, Y2 and Y3 can only sink current. The YCOM terminal must be tied to power supply (-)

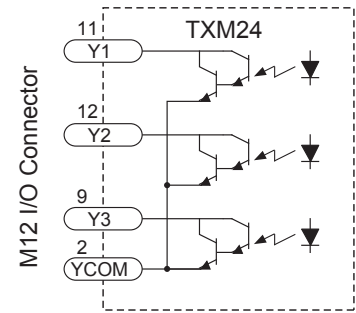

Diagrams of various connection types follow.

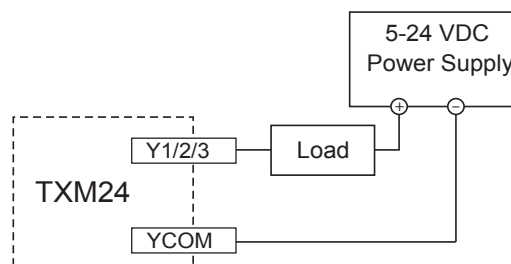

Sinking Output Using Y1, Y2 or Y3

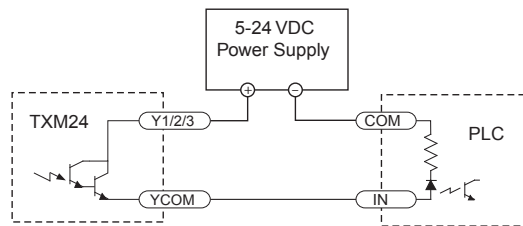

Sourcing Output Using Y1, Y2 or Y3

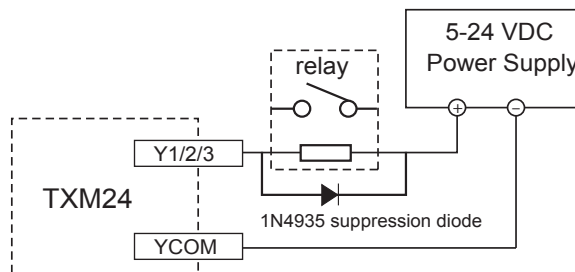

















Driving a Relay Using Y1, Y2 or Y3

Do not connect the output to more than 30 volts. The current through the output terminal must not exceed 100mA.

4 Troubleshooting

LED Error Codes

The TXM24C uses bi-colour LED to indicate status. When the motor is enabled, the green LED flashes slowly. When the green LED is solid, the motor is disabled. Errors are indicated by combinations of red and green flashes as shown below. This feature can be disabled for certain warnings but not for alarms.

	Code	Error
	Solid green	no alarm, motor disabled
	Flashing green	no alarm, motor enabled
	1 red, 1 green	motor stall (optional encoder only)
	2 red, 1 green	ccw limit
	2 red, 2 green	cw limit
	3 red, 1 green	drive overheating
	3 red, 2 green	internal voltage out of range
	3 red, 3 green	blank Q segment
	4 red, 1 green	power supply overvoltage or excess regen
	4 red, 2 green	power supply undervoltage
	4 red, 3 green	flash memory backup error
	5 red, 1 green	Over current/short circuit
	6 red, 1 green	Open motor winding
	6 red, 2 green	bad encoder signal (optional encoder only)
	7 red, 1 green	communication error
	7 red, 2 green	flash memory error

5 Reference Materials

5.1 Torque-Speed Curves

Note: all torque curves were measured at 20,000 steps/rev.

Note: 6 amp rating is continuous, 7.5 amp rating is boost

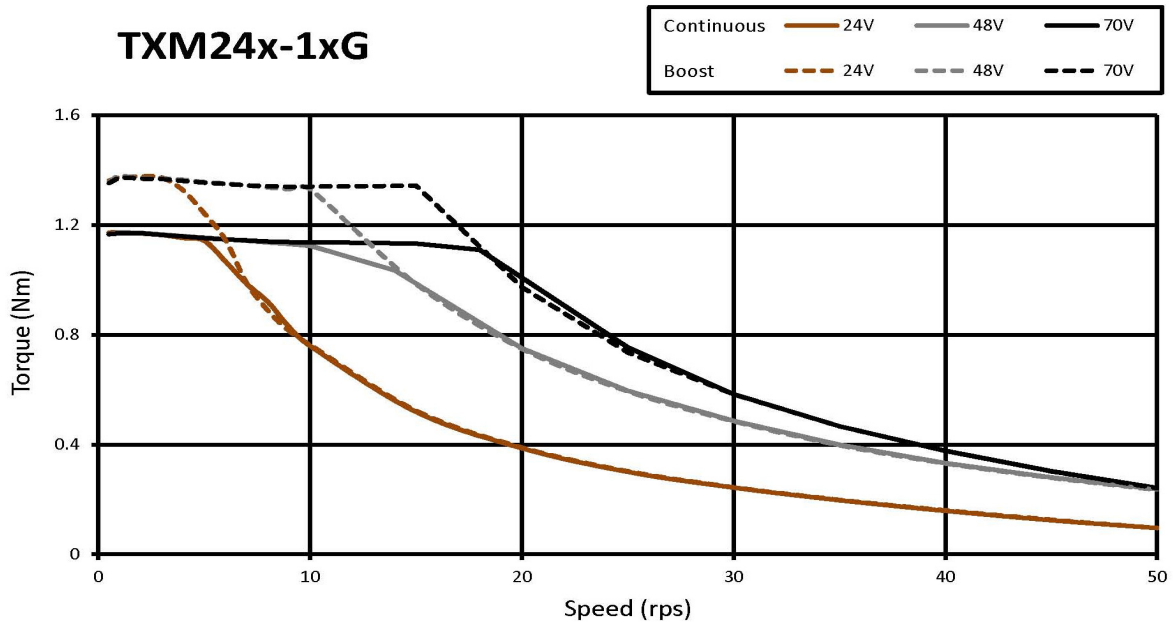
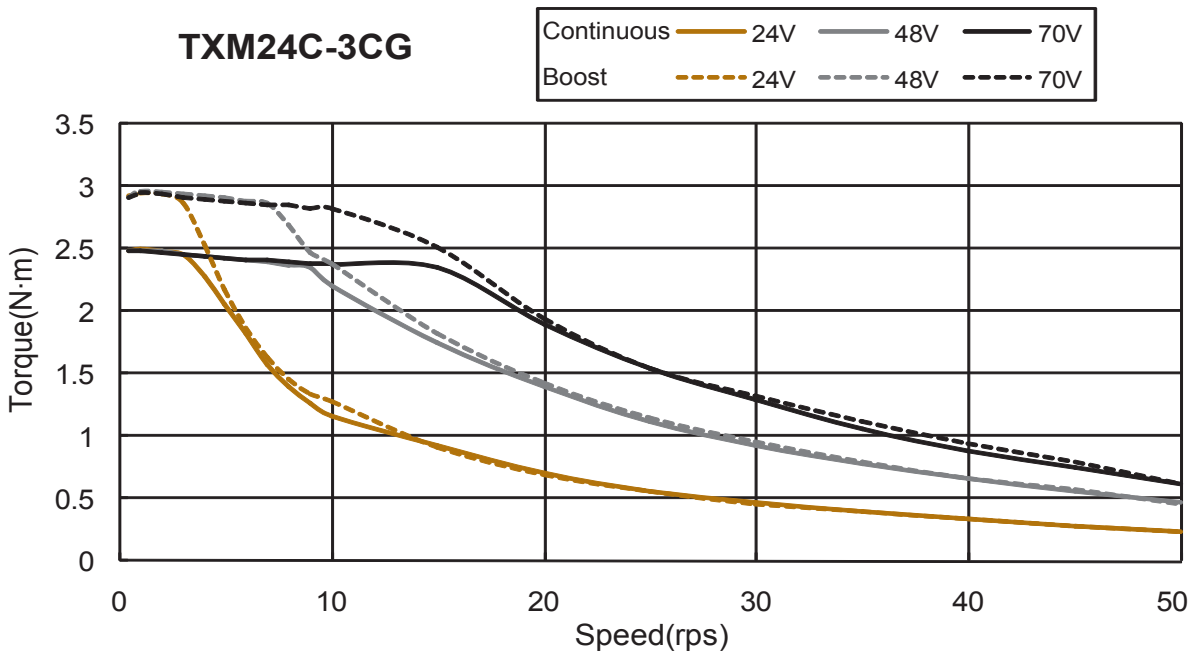

5.2 Mechanical Outlines

TXM24C-1CG

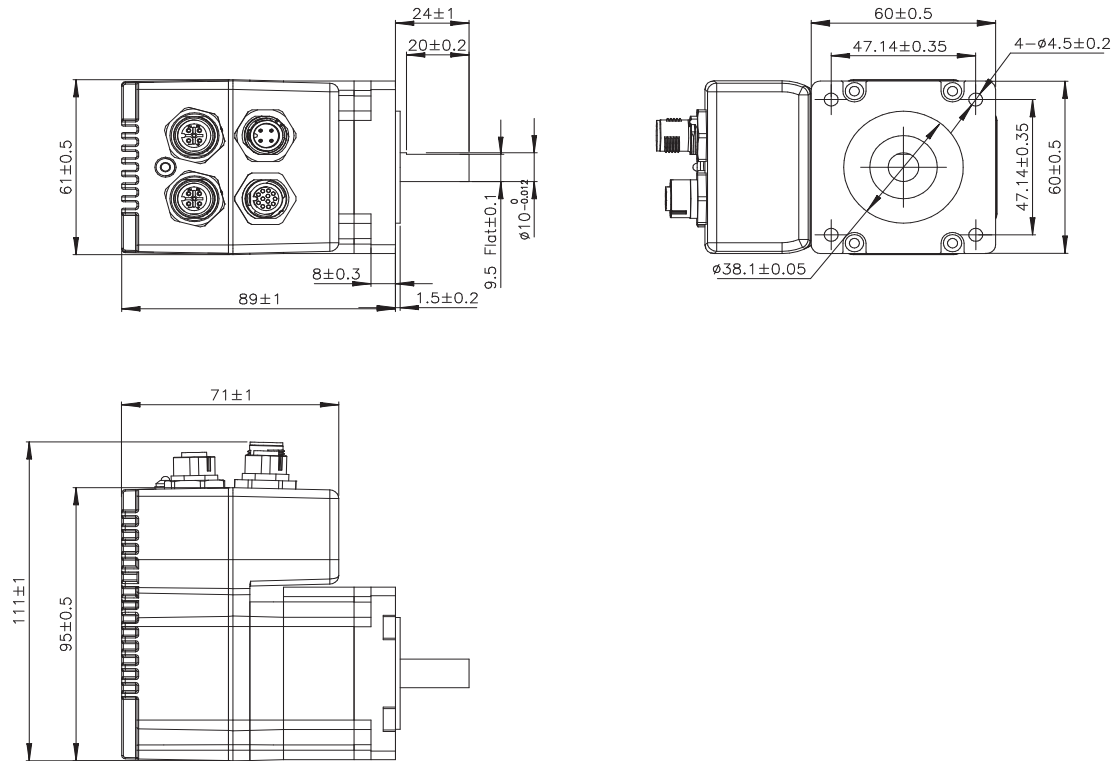

TXM24C-3CG

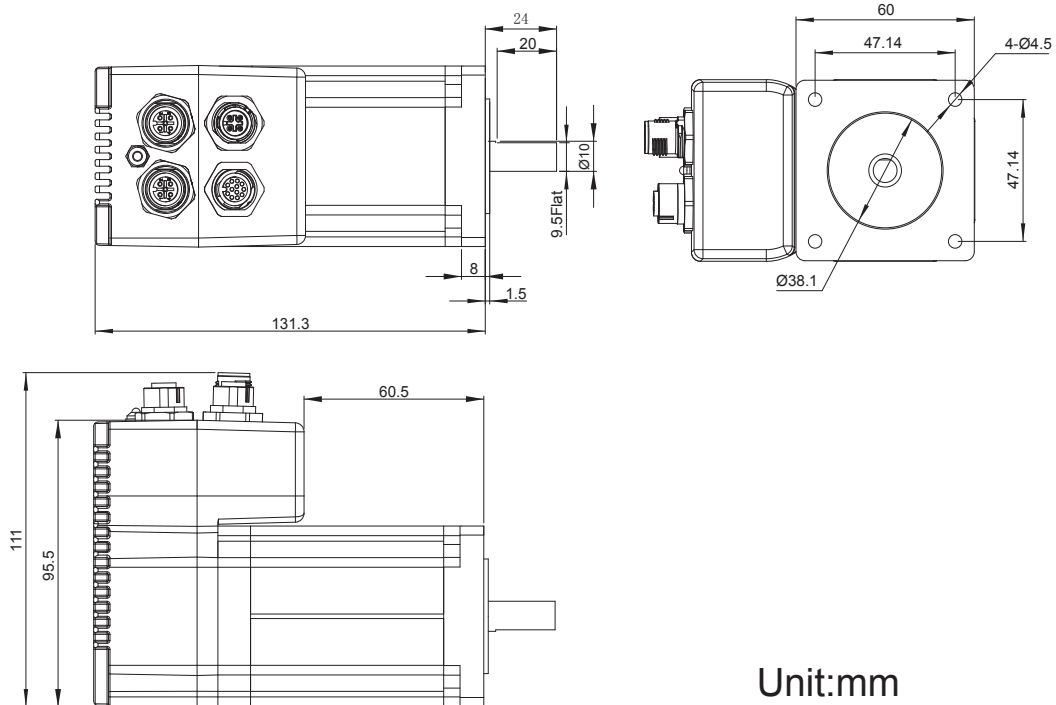

Unit:mm

5.3 Technical Specifications

Power Amplifier	
Amplifier Type	Dual H-Bridge, 4 Quadrant
Current Control	4 state PWM at 20 KHz
Output Torque	TXM24C-1CG: Up to 0.82N•m Continuous (1.03 N•m Boost) TXM24C-3CG: Up to 2.4N•m Continuous (3.0 N•m Boost)
Power Supply	External 12 - 70 VDC power supply required
Protection	Over-voltage, under-voltage, over-temp, motor/wiring shorts (phase-to-phase, phase-to-ground)
Controller	
Electronic Gearing	Software selectable from 200 to 51200 steps/rev in increments of 2 steps/rev
Encoder Resolution	20000 counts/rev
Speed Range	Up to 3600rpm
Filters	PID filter, Notch filter
Non-Volatile Storage	Configurations are saved in FLASH memory on-board the DSP
Modes of Operation	CANopen slave node plus stored Q Program execution
Digital Inputs	X1, X2 inputs: Optically isolated, differential, 5-24 VDC logic (2.5V switching threshold), 50 usec minimum pulse width, maximum current = 10 mA. X3-X5 inputs: Optically isolated, single-ended, shared common. sinking or sourcing, 5-24 VDC logic, maximum current = 10 mA.
Digital Output	Y1-Y3 outputs: Optical darlington, single-ended, shared, sinking, 30 VDC max, 100 mA max, voltage drop = 1.2V max at 100 mA. Function: Fault, tach, in position, brake, or general purpose programmable
Communication Interface	CANopen, RS-232
Physical	
Ambient Temperature	0 to 40°C (32 to 104°F) When mounted to a suitable heatsink
Humidity	90% Max., non-condensing
Mass	TXM24C-1CG: 1049 g = 37 oz TXM24C-3CG: 2000 g = 70.55 oz
Rotor Inertia	TXM24C-1CG: 260 g•cm ² = 3.97E-03 oz-in-S ² TXM24C-3CG: 900 g•cm ² = 1.27 X 10 ⁻² oz-in-S ²
Length	TXM24C-1CG: 3.5 inches (88.9mm) TXM24C-3CG: 5.15 inches (130.8mm)

5.4 Accessories

Mating Cables

Position	Part Number	Description
Power	3004-277-5M	4-pin Mating Cable, M12, 2.0m, 22AWG, straight
I/O	3004-290-5M	12-pin Mating Cable, M12, 1.5m, 26AWG, straight
RS-232 & CANopen X2	3004-288-5M	5-pin Mating Cable, M12 1.5m 22AWG, straight

Sold & Serviced By:



Toll Free Phone (877) SERV098

Toll Free Fax (877) SERV099

www.electromate.com

sales@electromate.com