

# FM060-5-RM

FlexPro® Series

**Product Status:** Active

## SPECIFICATIONS

Current Peak	<b>10 A</b>
Current Continuous	<b>5 A</b>
DC Supply Voltage	<b>10 – 55 VDC</b>
Network Communication	<b>RS485/232</b>

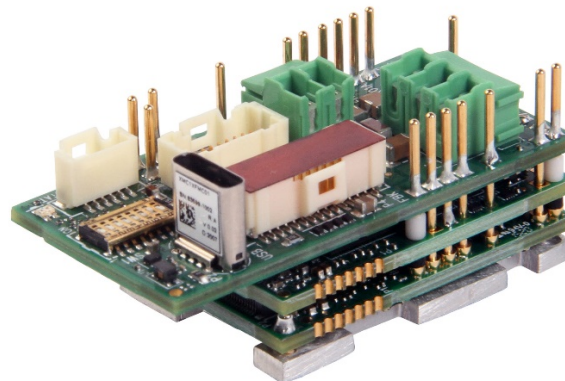

The **FM060-5-RM** is a single-axis servo drive and integration board assembly for a FE060-5-RM FlexPro® series servo drive with IMPACT™ architecture. Connections to the controller, motor, power, and feedback are simplified through the standard connectors featured on the board.

The **FM060-5-RM** offers full tuning control of all servo loops and is designed to drive brushed and brushless servo motors, stepper motors, and AC induction motors. The drive accepts a variety of external command signals, or can use the built-in Motion Engine, an internal motion controller used with Sequencing and Indexing commands. Programmable digital and analog I/O are included to enhance interfacing with external controllers and devices.

The **FM060-5-RM** utilizes RS485/232 network communication and is configured via USB. All drive and motor parameters are stored in non-volatile memory.

IMPACT™ (Integrated Motion Platform And Control Technology) combines exceptional processing capability and high-current components to create powerful, compact, feature-loaded servo solutions. IMPACT™ is used in all FlexPro® drives and is available in custom products as well.

## FEATURES

- Standard Connections for Easy Setup
- Four Quadrant Regenerative Operation
- Programmable Gain Settings
- PIDF Velocity Loop
- On-the-Fly Mode Switching
- On-the-Fly Gain Set Switching
- Dedicated Safe Torque Off (STO) Inputs
- Bridge Status, Fault and Network Status LEDs
- I/O Status LEDs

<b>Feedback Supported</b>	<ul style="list-style-type: none"> <li>• Absolute Encoder               <ul style="list-style-type: none"> <li>○ BiSS C-Mode</li> <li>○ EnDat 2.2</li> </ul> </li> <li>• Incremental Encoder</li> <li>• Hall Sensors</li> <li>• ±10 VDC Position</li> <li>• Tachometer (±10V)</li> </ul>	<b>Motors Supported</b>	<ul style="list-style-type: none"> <li>• Three Phase</li> <li>• Single Phase</li> <li>• Stepper</li> <li>• AC Induction</li> </ul>	<b>Modes of Operation</b>	<ul style="list-style-type: none"> <li>• Current</li> <li>• Velocity</li> <li>• Position</li> </ul>
<b>Command Sources</b>	<ul style="list-style-type: none"> <li>• Over the Network</li> <li>• ±10V Analog</li> <li>• Sequencing</li> <li>• Indexing</li> <li>• Jogging</li> <li>• Step &amp; Direction</li> <li>• Encoder Following</li> </ul>	<b>Inputs / Outputs</b>	<ul style="list-style-type: none"> <li>• 4 Programmable Digital Inputs</li> <li>• 3 Programmable Digital Outputs</li> <li>• 1 Programmable Analog Input</li> </ul>	<b>Agency Approvals</b>	<ul style="list-style-type: none"> <li>• RoHS</li> <li>• UL (Pending)</li> <li>• CE (Pending)</li> <li>• TUV Rheinland (STO) (Pending)</li> </ul>

**BLOCK DIAGRAM**

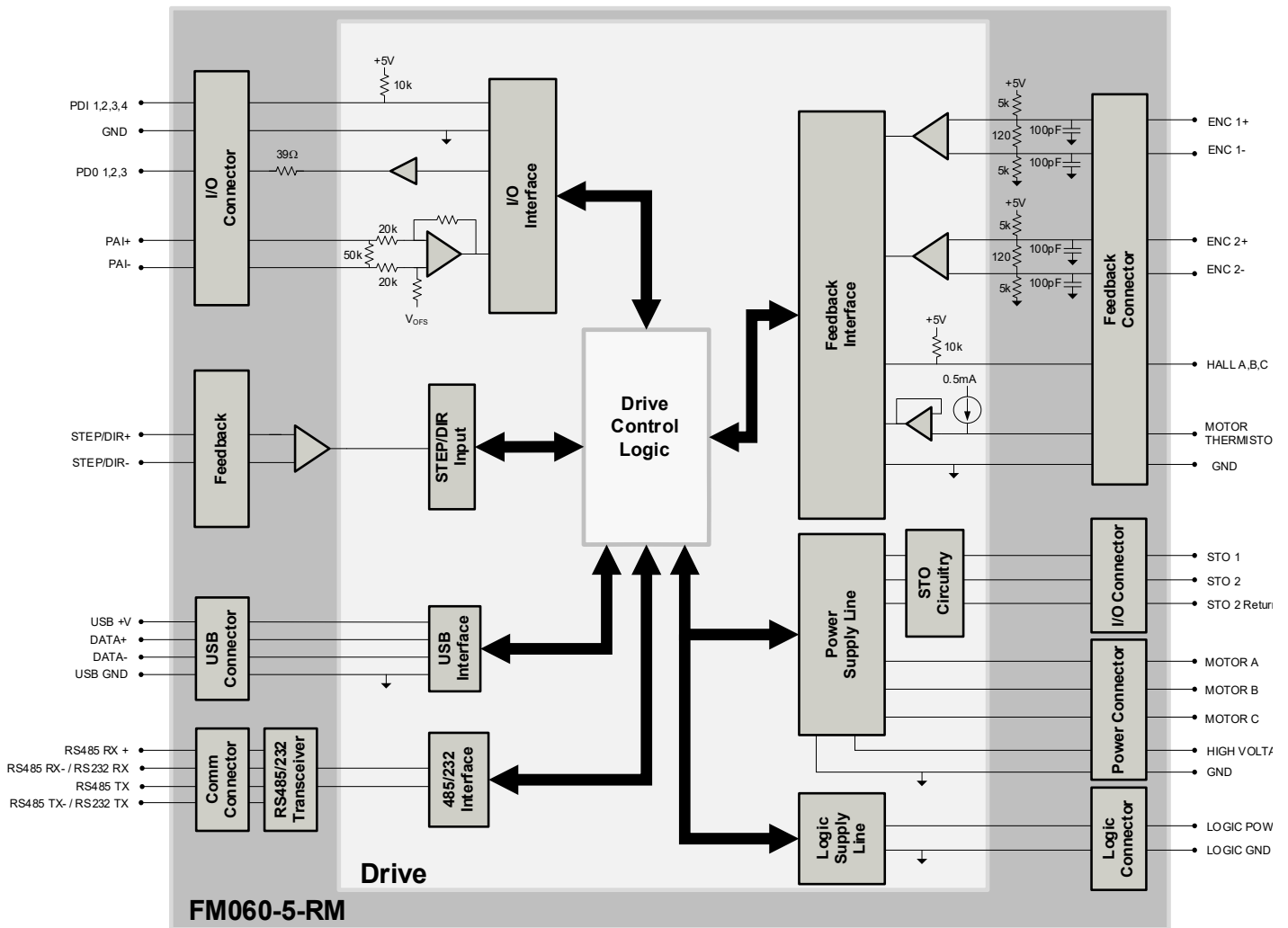

**INFORMATION ON APPROVALS AND COMPLIANCES**



The RoHS Directive restricts the use of certain substances including lead, mercury, cadmium, hexavalent chromium and halogenated flame retardants PBB and PBDE in electronic equipment.

Sold & Serviced By:

Canadian and International Sales  
  
**ELECTROMATE**  
 877-737-8698  
 sales@electromate.com  
 www.electromate.com

U.S. Sales  
  
**SERVO2GO.com**  
 877-378-0240  
 sales@servo2go.com  
 www.servo2go.com

**SPECIFICATIONS**

Description	Electrical Specifications		Value
	Units		
Nominal DC Supply Input Range	VDC	12 – 48	
DC Supply Input Range	VDC	10 – 55	
DC Supply Undervoltage	VDC	8	
DC Supply Overvoltage	VDC	58	
Logic Supply Input Range (optional)	VDC	10 – 55	
Safe Torque Off Voltage (Default)	VDC	5	
Maximum Peak Current Output <sup>1</sup>	A (Arms)	10 (7.07)	
Maximum Continuous Current Output <sup>2</sup>	A (Arms)	5 (5)	
Bus Capacitance <sup>3</sup>	μF	52.8	
Efficiency at Rated Power	%	99	
Maximum Continuous Output Power	W	272	
Maximum Power Dissipation at Continuous Current	W	3	
Minimum Load Inductance (line-to-line) <sup>4</sup>	μH	150 (@ 48VDC supply); 75 (@24VDC supply); 40 (@12VDC supply)	
Switching Frequency	kHz	20	
Maximum Output PWM Duty Cycle	%	83	

Description	Control Specifications		Value
	Units		
Communication Interfaces	-	RS485/232 (USB for configuration)	
Command Sources	-	±10 V Analog, Over the Network, Sequencing, Indexing, Jogging, Step & Direction, Encoder Following	
Feedback Supported	-	Absolute Encoder (BiSS C-Mode, EnDat 2.2), Incremental Encoder, Hall Sensors, Auxiliary Incremental Encoder, ±10 VDC Position, Tachometer (±10V)	
Commutation Methods	-	Sinusoidal, Trapezoidal	
Modes of Operation	-	Current, Velocity, Position	
Motors Supported <sup>5</sup>	-	Three Phase (Brushless Servo), Single Phase (Brushed Servo, Voice Coil, Inductive Load), Stepper (2- or 3-Phase Closed Loop), AC Induction (Closed Loop Vector)	
Hardware Protection	-	40+ Configurable Functions, Over Current, Over Temperature (Drive & Motor), Over Voltage, Short Circuit (Phase-Phase & Phase-Ground), Under Voltage	
Programmable Digital Inputs/Outputs	-	4/3	
Programmable Analog Inputs/Outputs	-	1/0	
Primary I/O Logic Level	-	5 VDC, not isolated	
Current Loop Sample Time	μs	50	
Velocity Loop Sample Time	μs	100	
Position Loop Sample Time	μs	100	
Maximum Encoder Frequency	MHz	20 (5 pre-quadrature)	

Description	Mechanical Specifications		Value
	Units		
Size (H x W x D)	mm (in)	50.8 x 25.4 x 22.0 (2.00 x 1.00 x 0.86)	
Weight	g (oz)	34 (1.2)	
Ambient Operating Temperature Range <sup>6</sup>	°C (°F)	0 – 65 (32 – 149)	
Storage Temperature Range	°C (°F)	-40 – 85 (-40 – 185)	
Relative Humidity	-	0-95%	
P1 CANopen COMMUNICATION CONNECTOR	-	6-pin, 1.0mm spaced single row vertical header	
P2 USB CONNECTOR	-	USB Type C, vertical entry	
P3 IO and LOGIC CONNECTOR	-	20-pin, 1.0mm spaced dual row vertical header	
P4 FEEDBACK CONNECTOR	-	30-pin, 1.0mm spaced dual row vertical header	
P5 POWER CONNECTOR	-	2-port, 3.5mm spaced vertical entry screw terminal	
P6 MOTOR POWER CONNECTOR	-	3-port, 3.5mm spaced vertical entry screw terminal	

**Notes**

- Capable of supplying drive rated peak current for 2 seconds with 10 second foldback to continuous value. Longer times are possible with lower current limits.
- Continuous  $A_{rms}$  value attainable when RMS Charge-Based Limiting is used.
- Applications with a supply voltage higher than 30VDC require a minimum external decoupling capacitance of 470μF / 100V added across HV and POWER GND.
- Lower inductance is acceptable for bus voltages well below maximum. Use external inductance to meet requirements.
- Maximum motor speed for stepper motors is 600 RPM. Consult the hardware installation manual for 2-phase stepper wiring configuration.
- Additional cooling and/or heatsink may be required to achieve rated performance.

**PIN FUNCTIONS**

P1 – Communication Connector			
Pin	Name	Description / Notes	I/O
1	RS485 TX+	Transmit Line (RS485)	I/O
2	RS485 RX+	Receive Line (RS485)	I/O
3	RS485 TX- / RS232 TX	Transmit Line (RS485 or RS232)	I/O
4	RS485 RX- / RS232 RX	Receive Line (RS485 or RS232)	I/O
5	GND	Ground	GND
6	SHIELD	CAN shield	-
<b>Connector Information</b>		6-pin, 1.0mm spaced single row vertical header	
<b>Mating Connector Details</b>		Molex: 5013300600	
<b>Mating Connector Included</b>		No	

P2 – USB Connector			
Pin	Name	Description / Notes	I/O
<b>Connector Information</b>		USB Type C port	
<b>Mating Connector Details</b>		Standard Type C USB connection cable	
<b>Mating Connector Included</b>		No	

P3 – I/O and Logic Connector			
Pin	Name	Description / Notes	I/O
1	PDI-1	General Purpose Programmable Digital Input	I
2	PDI-2	General Purpose Programmable Digital Input	I
3	PDI-3	General Purpose Programmable Digital Input	I
4	PDI-4	General Purpose Programmable Digital Input	I
5	PDO-1	General Purpose Programmable Digital Output (TTL/8mA)	O
6	PDO-2	General Purpose Programmable Digital Output (TTL/8mA)	O
7	PDO-3	General Purpose Programmable Digital Output (TTL/8mA)	O
8	GND	Ground.	GND
9	+5V USER	+5V Supply Output. Short-circuit protected. (300ma total load capacity shared between P3-9, P4-1, P4-13, and P4-21)	O
10	GND	Ground.	GND
11	PAI-1+	General Purpose Differential Programmable Analog Input or Reference Signal Input. ±10VDC Range (12-bit Resolution)	I
12	PAI-1-		I
13	STO-1 INPUT	Safe Torque Off – Input 1	I
14	STO RETURN	Safe Torque Off Return	STORET
15	STO-2 INPUT	Safe Torque Off – Input 2	I
16	STO RETURN	Safe Torque Off Return	STORET
17	RESERVED / NC	Reserved.	-
18	GND	Ground.	GND
19	LOGIC PWR	Logic Supply Input (10 – 55VDC) (optional)	I
20	LOGIC GND	Ground	GND
<b>Connector Information</b>		20-pin, 1.0mm spaced dual row vertical header	
<b>Mating Connector Details</b>		Molex: 501892010	
<b>Mating Connector Included</b>		No	

P4 – Feedback Connector				
Pin	Absolute Encoder	Incremental Encoder	Description / Notes	I/O
1	+5V USER	+5V USER	+5V Supply Output. Short-circuit protected. (300ma total load capacity shared between P3-9, P4-1, P4-13, and P4-21)	O
2	GND	GND	Ground.	GND
3	HALL A	HALL A	Single-ended Commutation Sensor Inputs.	I
4	HALL B	HALL B		I
5	HALL C	HALL C		I
6	THERMISTOR	THERMISTOR	Motor Thermal Protection.	I
7	ENC 2 A+	ENC 2 A+	Differential Incremental Encoder A.	I
8	ENC 2 A-	ENC 2 A-		I
9	ENC 2 B+	ENC 2 B+	Differential Incremental Encoder B.	I
10	ENC 2 B-	ENC 2 B-		I
11	ENC 2 I+	ENC 2 I+	Differential Incremental Encoder Index.	I
12	ENC 2 I-	ENC 2 I-		I
13	+5V USER	+5V USER	+5V Supply Output. Short-circuit protected. (300ma total load capacity shared between P3-9, P4-1, P4-13, and P4-21)	O
14	GND	GND	Ground.	GND
15	STEP +	STEP +	Differential Step Input.	I
16	STEP -	STEP -		I
17	DIR +	DIR +	Differential Direction Input.	I
18	DIR -	DIR -		I
19	RESERVED	RESERVED	Reserved.	-
20	RESERVED	RESERVED		-
21	+5V USER	+5V USER	+5V Supply Output. Short-circuit protected. (300ma total load capacity shared between P3-9, P4-1, P4-13, and P4-21)	O
22	GND	GND	Ground.	GND
23	ENC 1 DATA+	ENC 1 A+	Differential Data Line for Absolute Encoders (BiSS: SLO+/-) or Differential Incremental Encoder A.	I
24	ENC 1 DATA-	ENC 1 A-		I
25	ENC 1 CLOCK+	ENC 1 B+	Differential Clock Line for Absolute Encoders (BiSS: MA+/-) or Differential Incremental Encoder B.	I
26	ENC 1 CLOCK-	ENC 1 B-		I
27	ENC 1 REF MARK+	ENC 1 I+	Differential Reference Mark for Absolute Encoders (Leave open for BiSS and EnDat 2.2) or Differential Incremental Encoder Index.	I
28	ENC 1 REF MARK-	ENC 1 I-		I
29	RESERVED	RESERVED	Reserved.	-
30	RESERVED	RESERVED	Reserved.	-

<b>Connector Information</b>	30-pin, 1.0mm spaced dual row vertical header	
<b>Mating Connector Details</b>	Molex: 5011893010	
<b>Mating Connector Included</b>	No	

## Sold & Serviced By:



*Canadian and International Sales*

# ELECTROMATE

**877-737-8698**
[sales@electromate.com](mailto:sales@electromate.com)
[www.electromate.com](http://www.electromate.com)
*U.S. Sales*

# SERVO2GO.com

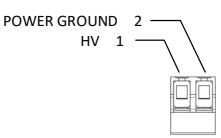
**877-378-0240**
[sales@servo2go.com](mailto:sales@servo2go.com)
[www.servo2go.com](http://www.servo2go.com)

P5 - Power Connector			
Pin	Name	Description / Notes	I/O
1	HV	DC Supply Input. Applications with a supply voltage higher than 30VDC require a minimum external decoupling capacitance of 470µF / 100V added across HV and POWER GND.	I
2	POWER GND	Ground.	GND
<b>Connector Information</b>		2-port 3.5mm spaced vertical entry screw terminal	
<b>Mating Connector Details</b>		N/A	
<b>Mating Connector Included</b>		N/A	

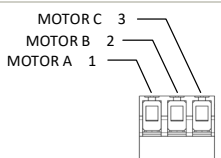
P6 - Motor Power Connector			
Pin	Name	Description / Notes	I/O
1	MOTOR A	Motor Phase A.	O
2	MOTOR B	Motor Phase B.	O
3	MOTOR C	Motor Phase C.	O
<b>Connector Information</b>		3-port 3.5mm spaced vertical entry screw terminal	
<b>Mating Connector Details</b>		N/A	
<b>Mating Connector Included</b>		N/A	

Sold & Serviced By:



Canadian and International Sales  
**ELECTROMATE**  
 877-737-8698  
[sales@electromate.com](mailto:sales@electromate.com)  
[www.electromate.com](http://www.electromate.com)

U.S. Sales  
  
**SERVO2GO.com**  
 877-378-0240  
[sales@servo2go.com](mailto:sales@servo2go.com)  
[www.servo2go.com](http://www.servo2go.com)

## BOARD CONFIGURATION

### Status LED Functions

LED	Description
STAT	Indicates drive power bridge status. GREEN when DC bus power is applied and the drive is enabled. RED when the drive is in a fault state.
LOGIC PWR	Indicates that +5V logic power is available to the drive. GREEN when +5V logic power is available.

### Switch Settings

The RS485/232 drive address and baud rate are set using DIP Switch SW1. Switch settings are given in the below table.

SW1	Description	On	Off
1	Bit 0 of binary RS485/232 address.	On = 1, Off = 0. Note that setting all addressing switches to 0 will use the address stored in NVM. Default setting is NVM address.	
2	Bit 1 of binary RS485/232 address.		
3	Bit 2 of binary RS485/232 address.		
4	RS485/RS232 Select	RS485	RS232 (default)
5	Baud Rate	115.2k	Set via software (default)
6	RS485 2-wire / 4-wire Select	2-wire	4-wire (default)
7	RS485 2-wire / 4-wire Select		
8	Network Termination	Terminated	Not Terminated (default)

### Safe Torque Off (STO) Inputs

The Safe Torque Off (STO) inputs are dedicated +5VDC sinking single-ended inputs. For applications not using STO functionality, disabling of the STO feature is required for proper drive operation. STO may be disabled by following the STO Disable wiring instructions as given in the hardware installation manual.

### Mating Connector Kit

Mating connector housing and crimp contacts can be ordered as a kit using ADVANCED Motion Controls' part number KC-MC1XFM01. This includes mating connector housing and crimp style contacts for the Communication, I/O and Logic, and Feedback connectors. The recommended tool for crimping the contacts is Molex PN: 63819-1500 (not included with the kit).

## Sold & Serviced By:



Canadian and International Sales

# ELECTROMATE

877-737-8698

[sales@electromate.com](mailto:sales@electromate.com)

[www.electromate.com](http://www.electromate.com)

U.S. Sales

# SERVO2GO.com

877-378-0240

[sales@servo2go.com](mailto:sales@servo2go.com)

[www.servo2go.com](http://www.servo2go.com)

**MOUNTING DIMENSIONS**

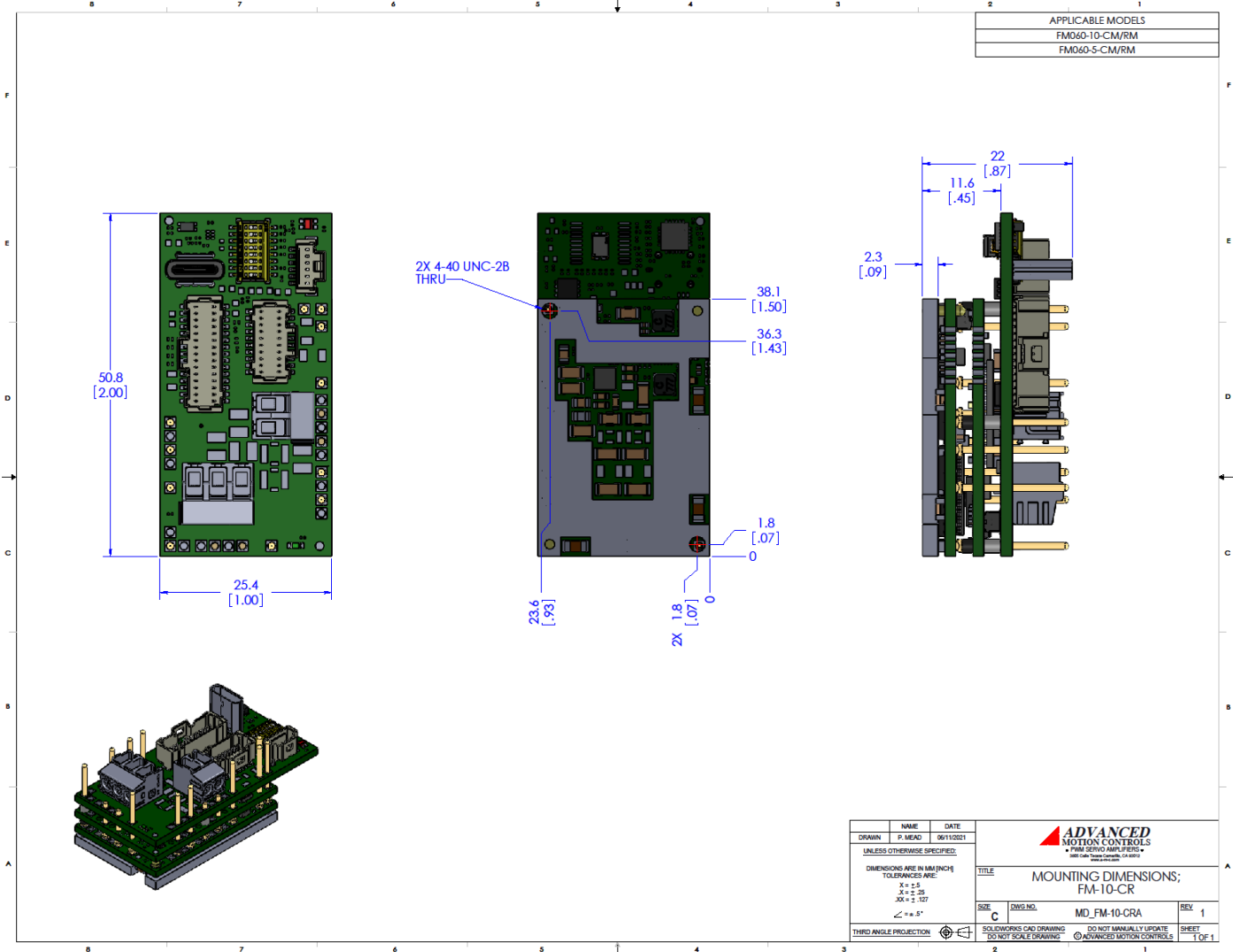

Sold & Serviced By:



Canadian and International Sales

**ELECTROMATE**

877-737-8698  
sales@electromate.com  
www.electromate.com

U.S. Sales



877-378-0240  
sales@servo2go.com  
www.servo2go.com



**PART NUMBERING AND CUSTOMIZATION INFORMATION**

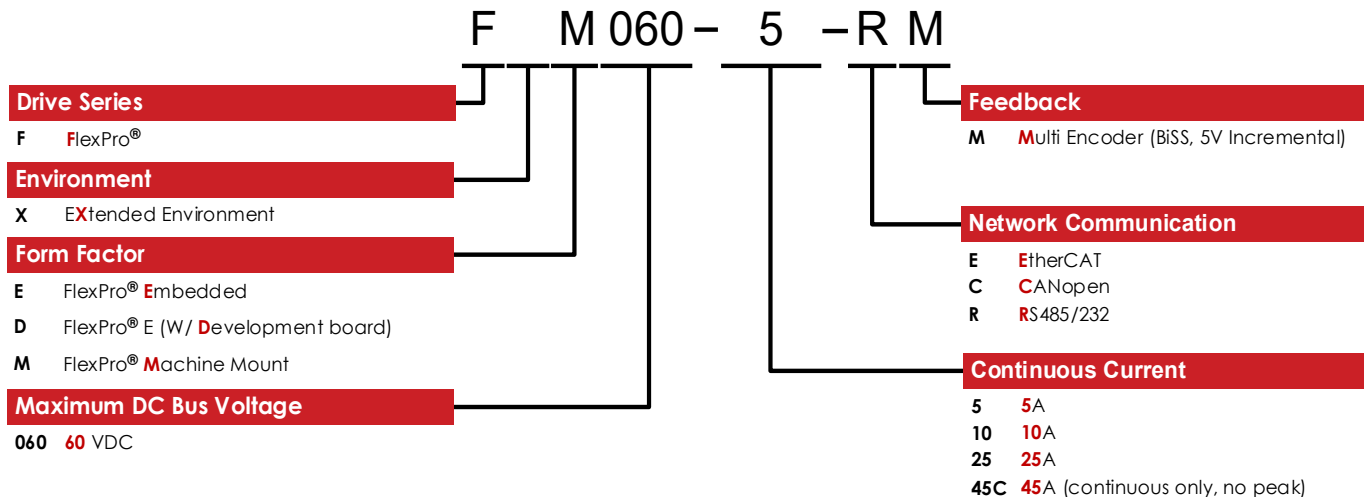

ADVANCED Motion Controls also has the capability to promptly develop and deliver specified products for OEMs with volume requests. Our Applications and Engineering Departments will work closely with your design team through all stages of development in order to provide the best servo drive solution for your system. Equipped with on-site manufacturing for quick-turn customs capabilities, ADVANCED Motion Controls utilizes our years of engineering and manufacturing expertise to decrease your costs and time-to-market while increasing system quality and reliability.

**Examples of Customized Products**

- |  |  |
|--|--|
| <ul style="list-style-type: none"> <li>▲ Optimized Footprint</li> <li>▲ Private Label Software</li> <li>▲ OEM Specified Connectors</li> <li>▲ No Outer Case</li> <li>▲ Increased Current Resolution</li> <li>▲ Increased Temperature Range</li> <li>▲ Custom Control Interface</li> <li>▲ Integrated System I/O</li> </ul> | <ul style="list-style-type: none"> <li>▲ Tailored Project File</li> <li>▲ Silkscreen Branding</li> <li>▲ Optimized Base Plate</li> <li>▲ Increased Current Limits</li> <li>▲ Increased Voltage Range</li> <li>▲ Conformal Coating</li> <li>▲ Multi-Axis Configurations</li> <li>▲ Reduced Profile Size and Weight</li> </ul> |
|--|--|

Feel free to contact us for further information and details!

**Available Accessories**

ADVANCED Motion Controls offers a variety of accessories designed to facilitate drive integration into a servo system. Visit [www.a-m-c.com](http://www.a-m-c.com) to see which accessories will assist with your application design and implementation.

**Sold & Serviced By:**

Canadian and International Sales  
**ELECTROMATE**  
877-737-8698  
[sales@electromate.com](mailto:sales@electromate.com)  
[www.electromate.com](http://www.electromate.com)

U.S. Sales  
**SERVO2GO.com**  
877-378-0240  
[sales@servo2go.com](mailto:sales@servo2go.com)  
[www.servo2go.com](http://www.servo2go.com)

All specifications in this document are subject to change without written notice. Actual product may differ from pictures provided in this document.