

Hybrid Step Motors

SIZE
HT
17

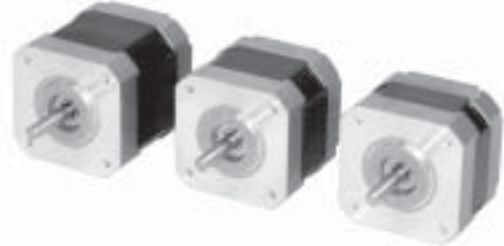
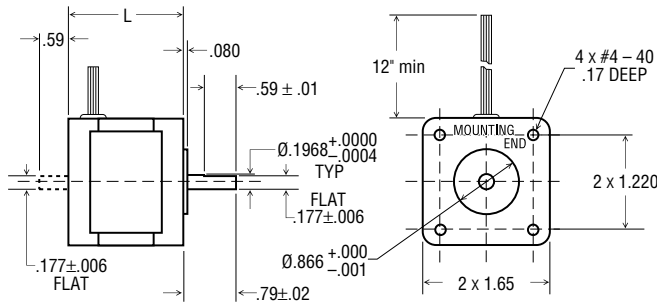

Part #	MOTOR CONNECTION 1 = series 2 = parallel 3 = unipolar	Motor Length (inches)	Minimum Holding Torque (oz-in)	Leads	Step Angle	Electrical				Rotor Inertia (oz-in ² /G-CM ²)	Motor Weight (Lbs.)
						Volts	Amps	Ohms	mH		
HT17-068	1	1.3	31.4	8	1.8	5.7	.67	8.4	11.2	.190/35.0	.44
	2	↓	31.4	↓	↓	2.8	1.34	2.1	2.8	↓	↓
	3	↓	22.2	↓	↓	4.0	0.95	4.2	2.8	↓	↓
HT17-069	1	↓	31.4	↓	↓	13.6	0.28	48.0	60.0	↓	↓
	2	↓	31.4	↓	↓	6.8	0.57	12.0	15.0	↓	↓
	3	↓	22.2	↓	↓	9.6	0.40	24.0	15.0	↓	↓
HT17-070	1	↓	31.4	↓	↓	17.5	0.22	80.0	88.0	↓	↓
	2	↓	31.4	↓	↓	8.8	0.44	20.0	22.0	↓	↓
	3	↓	22.2	↓	↓	12.4	0.31	40.0	22.0	↓	↓
HT17-071	1	1.54	51.0	↓	↓	5.7	0.85	6.6	14.4	.29/54.0	.57
	2	↓	51.0	↓	↓	2.8	1.70	1.7	3.6	↓	↓
	3	↓	36.1	↓	↓	4.0	1.20	3.3	3.6	↓	↓
HT17-072	1	↓	51.0	↓	↓	9.0	0.57	16.0	30.4	↓	↓
	2	↓	51.0	↓	↓	4.5	1.13	4.0	7.6	↓	↓
	3	↓	36.1	↓	↓	6.4	0.80	8.0	7.6	↓	↓

OTHER LENGTHS AND WINDINGS AVAILABLE UPON REQUEST

- Part numbers listed are for single shaft. To order double shaft add 'D' to the end.
- All HT17 motors are optimized for microstepping.

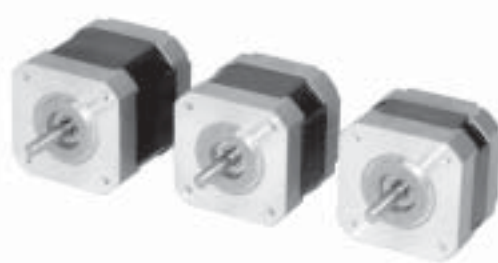
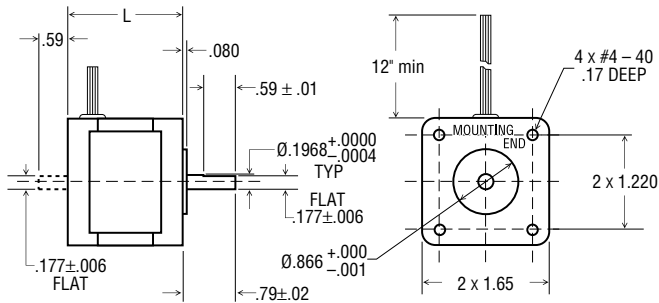

Part #	MOTOR CONNECTION			Minimum Holding Torque (oz-in)	Step Angle	Volts	Amps	Ohms	mH	Rotor Inertia (oz-in ² /G-CM ²)	Motor Weight (Lbs.)
	1 = series	2 = parallel	3 = unipolar								
HT17-073	1	1.54	51.0	8	1.8	17.0	0.28	60.0	120.0	.29/54.0	.57
	2	↓	51.0	↓	↓	8.5	0.57	15.0	30.0	↓	↓
	3	↓	36.1	↓	↓	12.0	0.40	30.0	30.0	↓	↓
HT17-074	1	↓	51.0	↓	↓	33.9	0.14	240.0	424.0	↓	↓
	2	↓	51.0	↓	↓	17.0	0.28	60.0	106.0	↓	↓
	3	↓	36.1	↓	↓	24.0	0.20	120.0	106.0	↓	↓
HT17-075	1	1.85	62.8	↓	↓	5.7	0.85	6.6	12.0	.37/68.0	.73
	2	↓	62.8	↓	↓	2.8	1.70	1.7	3.0	↓	↓
	3	↓	44.4	↓	↓	4.0	1.20	3.3	3.0	↓	↓
HT17-076	1	↓	62.8	↓	↓	10.2	0.57	18.0	38.0	↓	↓
	2	↓	62.8	↓	↓	5.1	1.13	4.5	9.5	↓	↓
	3	↓	44.4	↓	↓	7.2	0.80	9.0	9.5	↓	↓
HT17-077	1	↓	62.8	↓	↓	17.0	0.28	60.0	116.0	↓	↓
	2	↓	62.8	↓	↓	8.5	0.57	15.0	29.0	↓	↓
	3	↓	44.4	↓	↓	12.0	0.40	30.0	29.0	↓	↓

OTHER LENGTHS AND WINDINGS AVAILABLE UPON REQUEST

- Part numbers listed are for single shaft. To order double shaft add 'D' to the end.
- All HT17 motors are optimized for microstepping.

Size HT17 Motor

Typical Speed/Torque Performance*

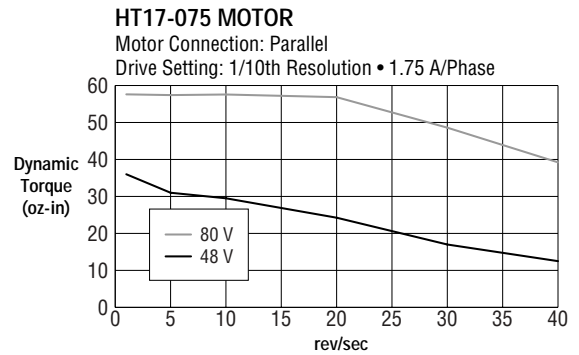
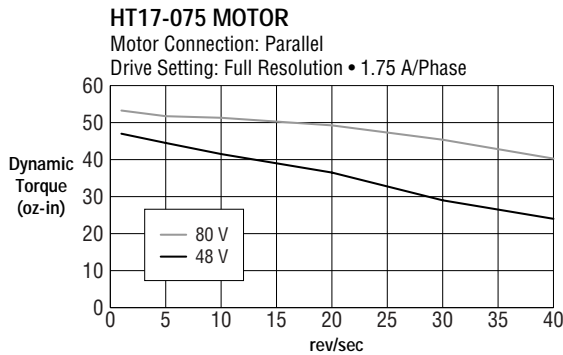
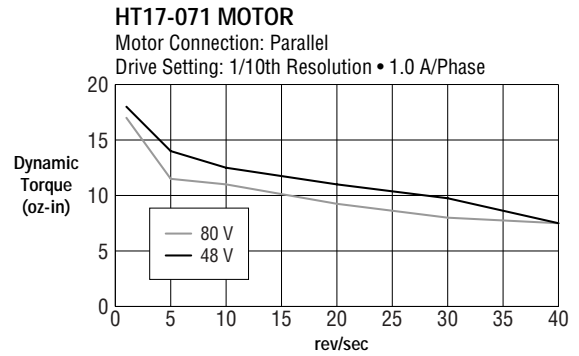
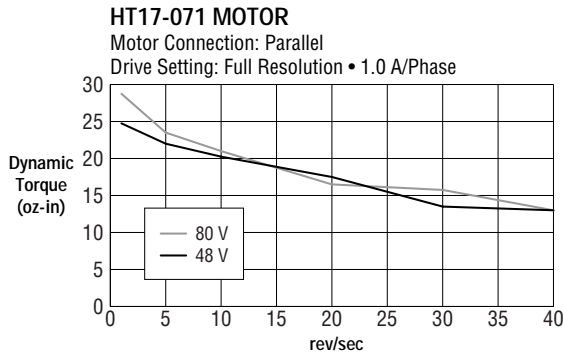
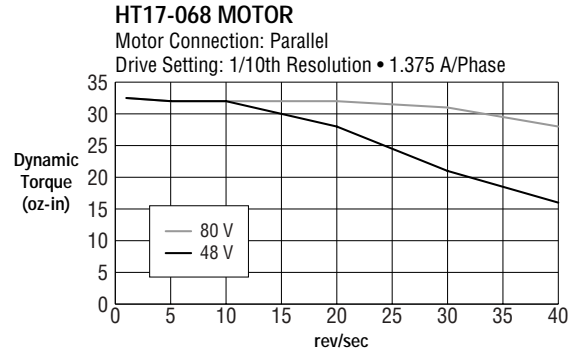
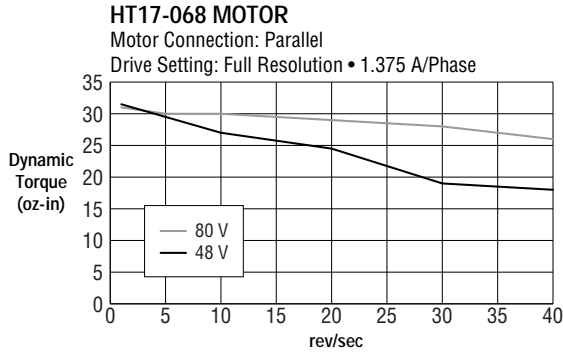

*Full steps/rev = Rev/sec x 200.