

---

*BMC 12H*

***HARDWARE INSTALLATION  
MANUAL***



## **Table Of Contents**

	Page
1.0 Overview of BMC 12H	1
1.1 BMC 12H Definition	1
1.2 Functional Block Diagram	1
1.3 Drive Features	1
1.4 General Specifications	2
1.5 System Connections / Wiring Diagram	2
1.6 How To Use This Manual	3
1.7 Warranty	3
2.0 Installing the BMC 12 H	4
2.1 Unpacking the Drive	4
2.2 Inspection Procedure	4
2.3 Storing the Drive	5
2.4 Selecting a Motor	5
2.5 Safety	6
2.6 Mechanical Installation	7
2.7 Electrical Interface and Connections	8
3.0 Operating / Configuration Mode Selection	14
3.1 Switch Functions	14
3.2 Potentiometer Functions	16
3.3 Torque (current) Mode	18
3.4 Hall Velocity Mode	20
3.5 Encoder Velocity Mode	22
3.6 Open Loop Mode	24
3.7 Tachometer Mode	26
4.0 maintenance and Troubleshooting	28
4.1 testing the BMC 12H Brushless Servo Drive	30
4.2 Defective Equipment	31
4.3 Return Procedure	31
Appendix A: Motor and Drive Selections	32
Appendix B: General Wiring Tips	33
Appendix C: Regenerative Operation and Considerations	35

# 1.0 Overview of BMC 12H

## 1.1 BMC 12H Definition

MCG BMC 12H is a PWM brushless servo drive designed to drive brushless type DC servo motors at a high switching frequency. Operating efficiencies approach 99 %.

## 1.2 Functional Block Diagram

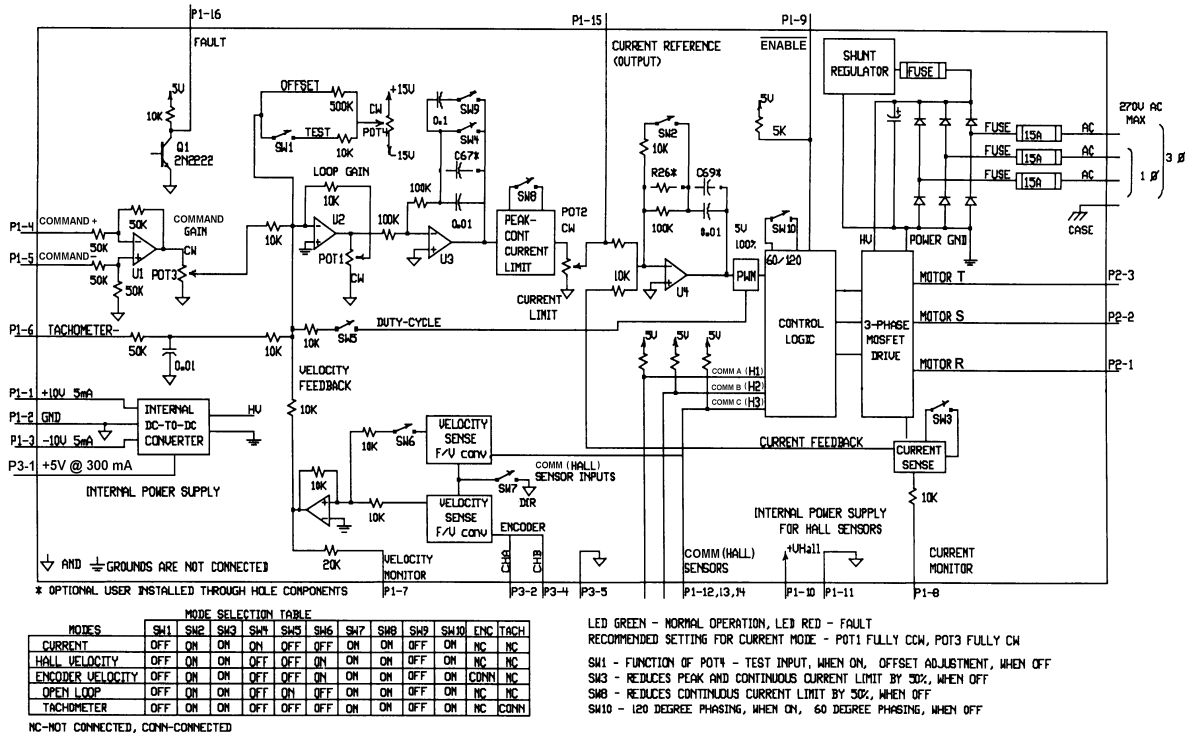

Figure (1) Functional Block Diagram

## 1.3 Drive Features

- Analog interface,  $\pm 10$  volts analog interface.
- Single red/green LED indicates operating status.
- Over voltage protection.
- Over current protection.
- Over temperature protection.
- Short circuit protection across motor, ground and power leads.
- Designed to interface with digital controllers or could be used as a stand-alone drive.
- Requires a single (1  $\phi$ ) phase or three (3  $\phi$ ) phase AC power source (70 - 270 Vac).
- Loop Gain, Current Limit, Command Gain and Offset can be adjusted using 15 turn potentiometers.
- The Offset adjusting potentiometer can also be used as an onboard input signal for testing purposes when SW-1 is ON (position 1 of the DIP switch is ON).
- Agency approvals, UL recognized.

## 1.4 General Specifications

	BMC 12H
Supply Voltage (1)	70 - 270 Vac
Peak Output Current (2 sec)	±25 Amp
Maximum Continuous Current	±12.5 Amp
Power Dissipation @ Cont. Current	55 Watts
Shunt Turn On	390 Volts DC

(1) Single or three phase operation.

Automatic Current Reduction	50 % OR 25 % Switch Selectable
Switching Frequency	20 kHz
Minimum Load Inductance	660 micro H
Input Command Signal Range	± 10 Volts (+-15 Volts DC max.)
Input Impedance	50 Kohms
Tach Input	60 Kohm, +- 60 Volts
Current Monitor Output	Amps to Volts
Velocity Monitor Output	RPM to Volts
Operating Temperature	32 - 122 F (0 - 50 C)
Storage Temperature	-40 - 176 F (-40 - 80 C)
Relative Humidity	5% - 95% non-condensing
Power Connectors	Screw Terminal
Signal Connector	Molex Connector
Size	8.00 X 6.35 X 3.43
Weight	4.8 lb

Specifications Table

## 1.5 System Connection/Wiring Diagram

The following diagram shows an installation of the BMC 12H in a typical system. Your system may vary from this configuration. Typical components used with the BMC 12H brushless servo drive include:

- Brushless DC servo motor.
- External switches.
- AC power source

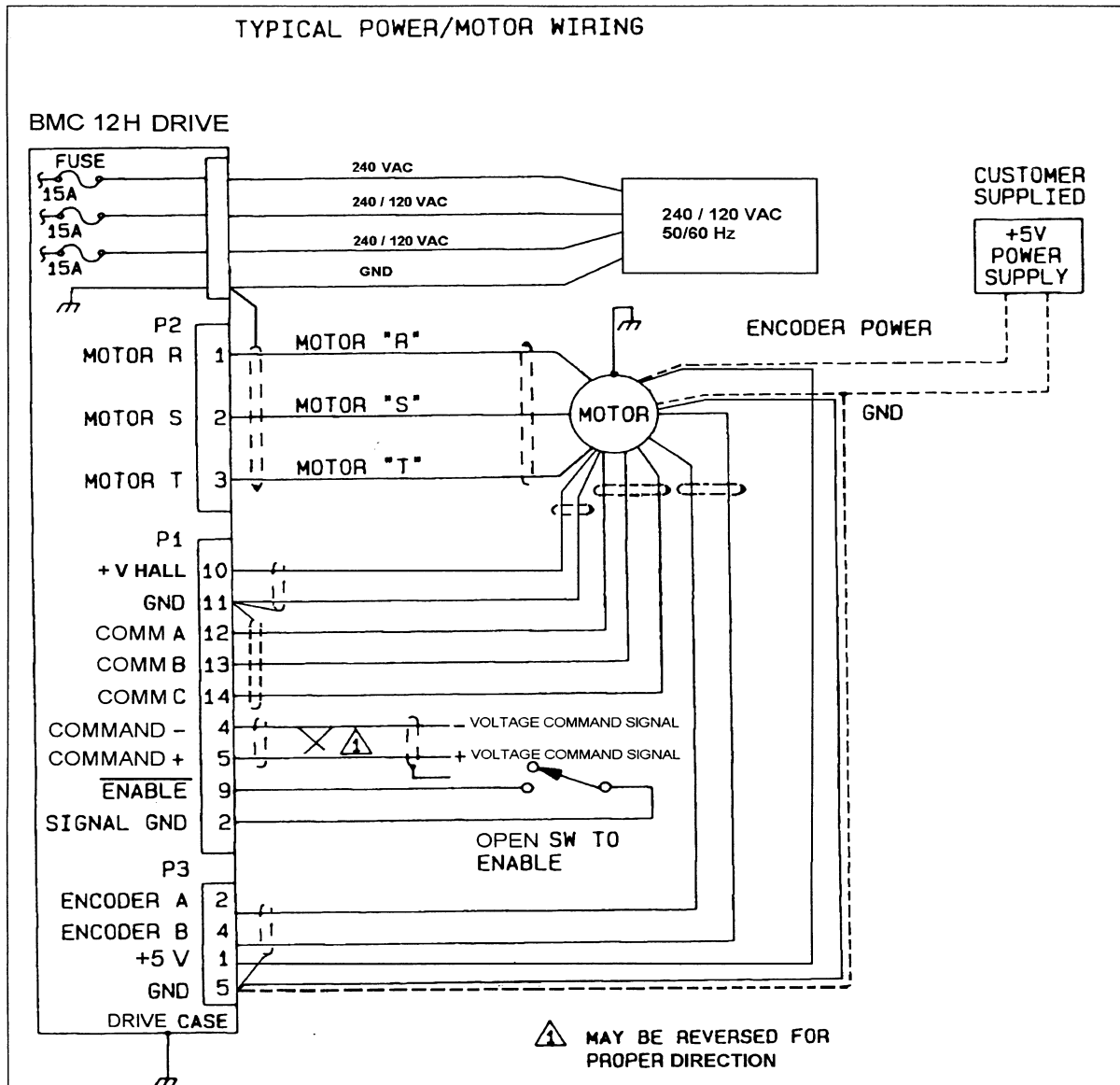

Figure (2) Wiring and Connections Diagram

## 1.6 How to Use This Manual

This manual provides and contains information, procedures and instructions on how to install, connect, set up and test the BMC 12H brushless servo drive. This manual is organized into chapters and appendices.

## 1.7 Warranty

The MCG BMC 12H has a two-year warranty against defects in material and assembly. Products that have been modified by the customer, physically mishandled or otherwise abused through miswiring, incorrect switch settings and so on, are exempt from the warranty plan.

## **2.0 Installing the BMC 12H**

This chapter explains how to install the BMC 12H brushless servo drive in your application.

### 2.1 Unpacking the Drive

- Remove the drive from the shipping carton and remove all packing materials from the brushless servo drive. The materials and the carton may be retained for storage or shipment of the drive.
- Check all items against the packing list. A label located on the side of the drive identifies:
  - Model number
  - Serial number
  - Manufacturing date code

### 2.2 Inspection Procedure

To protect your investment and ensure your rights under warranty, MCG recommends that the following steps be performed upon receipt of the drive:

- Inspect the drive for any physical damage that may have been sustained during shipment.
- Perform procedures described in section 2.2.1 before storing or installing the servo drive
- If you find damage, either concealed or obvious, contact your buyer to make claim with the shipper. Contact your distributor to obtain a **R**eturn **M**aterial **A**uthorization (RMA) number. Do this as soon as possible after you receive the BMC 12H drive.

#### 2.2.1 Testing the BMC 12H Brushless Servo Drive

The BMC 12H is designed to operate in a self-test mode using POT 4, the Offset / Test potentiometer, to control an onboard signal source. This test can be used to confirm that the servo drive is functional and operational. The test requires an AC power source (70 - 270 Vac, single or three phase), a multimeter, and a DC brushless servo motor.

1. Take note of the DIP switch settings before starting the test.
2. Always be prepared to turn the main power OFF.
3. Refer to figure (2) “Wiring and Connection Diagram.”
4. Set the DIP switch on the servo drive to the following settings, “positions”:

SW1	SW2	SW3	SW4	SW5	SW6	SW7	SW8	SW9	SW10	ENC	TACH
ON	OFF	OFF	OFF	ON	OFF	ON	OFF	OFF	ON	NC	NC

5. Set the “CURRENT LIMIT” POT 2 to the motor specifications, use the following table for the approximated current settings:

Number of turns from Fully CCW	SW3 OFF SW8 OFF		SW3 OFF SW8 ON		SW3 ON SW8 ON		SW3 ON SW8 OFF	
	I <sub>Cont</sub>	I <sub>Peak</sub>	I <sub>Cont</sub>	I <sub>Peak</sub>	I <sub>Cont</sub>	I <sub>Peak</sub>	I <sub>Cont</sub>	I <sub>Peak</sub>
5	±1.0	±4.17	±2.1	±4.2	±4.2	±8.4	±2.1	±8.4
10	±2.1	±8.4	±4.2	±8.4	±8.3	±16.7	±4.2	±16.8
15	±3.125	±12.5	±6.25	±12.5	±12.5	±25	±6.25	±25

6. Connect COMM A, B and C (hall) sensors to P1 pins 12, 13 and 14 3 respectively.
7. Connect the COMM (hall) power leads to P1-10, and COMM GND to P1-11.
8. **DO NOT CONNECT THE MOTOR LEADS (PHASES R, S AND T) YET.**
9. Connect your AC power, then apply power by turning the AC power source ON.
10. Check that the LED is GREEN (normal operation).
11. Turn the motor shaft manually one revolution; the LED should remain GREEN. If the LED is RED or changes color:
  - Check 60/120 degree phase switch setting (SW10, MCG setting is ON).
  - Check power to COMM (hall) sensors.
  - Check voltage levels for the COMM (hall) input.
12. Turn the AC power source OFF and wait for about 10 seconds (or till the LED is OFF).
13. Connect the motor leads, phases R, S and T to P2 pins 1, 2 and 3 respectively.
14. Turn the AC power source ON (LED should be GREEN for normal operation).
15. Verify smooth operation by turning the “TEST/OFFSET” potentiometer, POT 4, fully CW then fully CCW; motor should run smooth and reverse in both directions.
16. Turn the “TEST/OFFSET” potentiometer, POT 4, till the motor stops rotating.
17. Turn the AC power source OFF.
18. Set the DIP switch settings to the original factory settings or to your suitable mode.

If the drive passed the above test, proceed to the next section and if not refer to section 4.0 “Maintenance / Troubleshooting.”

## 2.3 Storing the Drive

Return the drive to its shipping carton using the original packing materials. Store the drive in a clean, dry place that will not exceed the following conditions:

- Humidity: 5% to 95%, non-condensing.
- Storage temperature: -40 - 176 F (-40 to 80 degrees C).

## 2.4 Selecting a Motor

The BMC 12H brushless servo drive is compatible with many brushless DC servo motors, both MCG brushless DC servo motors and motors from other manufacturers. The motor winding current rating must be equal or less to the output current setting of the drive.

Refer to the torque speed curve in the **CID** “Brushless Servo Components” catalog or contact your local MCG distributor for motor sizing and compatibility assistance.

## 2.5 Safety

Read the complete manual before attempting to install or operate the BMC 12H drive. By reading the manual you will become familiar with practices and procedures that allow you to operate this drive safely and effectively.

As a user or person installing this drive, you are responsible for determining the suitability of this product for the intended application. MCG is neither responsible for nor liable for indirect or consequential damage resulting from the inappropriate use of this product.

### 2.5.1 Safety Guidelines

Electrical shock and hazards are avoided by using normal installation procedures for electrical power equipment in an industrial environment. The drive should be installed in an industrial cabinet such that access is restricted to suitable qualified personnel.

- Electrical hazards can be avoided by disconnecting the drive from its power source and measuring the AC voltage to verify that it is within the safe level (70 - 270 Vac).
- Make sure motor case is tied to earth ground.
- DO NOT power the unit without the cover.
- DO NOT operate the unit without connecting the motor to the appropriate terminals. High voltage is present at the motor terminal, even when motor is not connected.
- Always remove power before making any connection to the drive.
- Always turn OFF the main power before taking the cover off the drive.
- DO NOT make any connections to the internal circuitry. Connections on the front panel are the only points where users should make connections.
- DO NOT use the ENABLE input as a safety shutdown. Always remove power to the drive for safety shutdown.
- Make sure the minimum inductance requirement is met.
- DO NOT spin the motor without power. The motor acts like a generator and will charge up the power capacitor through the drive. Excessive speed may cause over voltage breakdown in the power MOSFETs. Note that the drive, having an internal power converter, which operates from the high voltage, will become operative.
- DO NOT short the motor at high speed. When the motor is shorted, its own generated voltage may produce a current flow as high as 10 times the drive peak current. The short itself should not damage the drive but may damage the motor. If the motor is spinning rapidly and the motor connections arc or open, a high voltage pulse flows back into the drive (due to stored energy in the motor inductance) and may damage the drive.

### **WARNING**

*Voltage potential inside the drive varies from 380 Volts above to 380 Volts below earth ground. All internal circuitry should be considered “hot” when power is present.*

## 2.6 Mechanical Installation

Mount the drive in an enclosure providing protection to IP54, protected against dust and splashing water, or IP65, protected against water jets and dust free air. Many NEMA type 4 cabinets provide this level of protection. Minimum cabinet requirements are:

- Depth 7 inches.
- Ventilation to dissipate 55 watts.
- The air should also be free of corrosive or electrically conductive contaminants.
- Internal cabinet temperature should not exceed 122 F (50 degrees C). Operating temperature range is 32 - 122 F (0 - 50 degrees C).

### 2.6.1 Mounting Dimensions

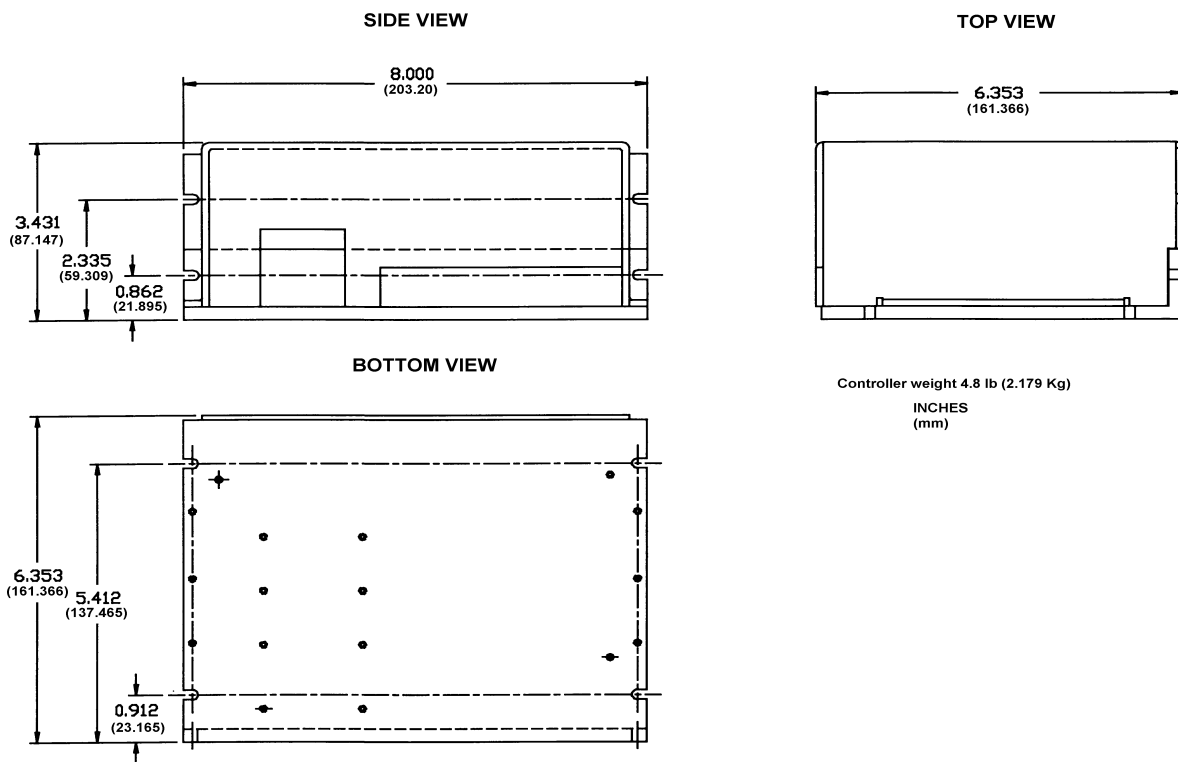

Figure (3) Mechanical Dimensions

Position the drive in vertical position on a flat, solid surface. This surface should be able to support 4.8 lb (2.2 Kg), the approximate weight of the drive.

- Bolt the drive in the cabinet using the two mounting slots in the rear side, or the four mounting slots in the side of the drive (cold plate mounting), using M4 or size 6-32 screws.
- Maintain a minimum unobstructed distance of 4 inches (100 mm) at the top and bottom of the drive.
- Maintain a minimum distance of one inch on each side of the drive.
- The surface should be free of excessive vibration or shock.

## 2.7 Electrical Interfacing and Connections

The servo drive has three I/O (input/output) connectors.

- P1 - Signal connector, Molex type, 16-pin connector.
- P2 - Motor connector, screw terminal, 3-pin connector.
- P3 - Encoder connector, Molex type, 5-pin connector.

### 2.7.1 Interface Connection Diagram

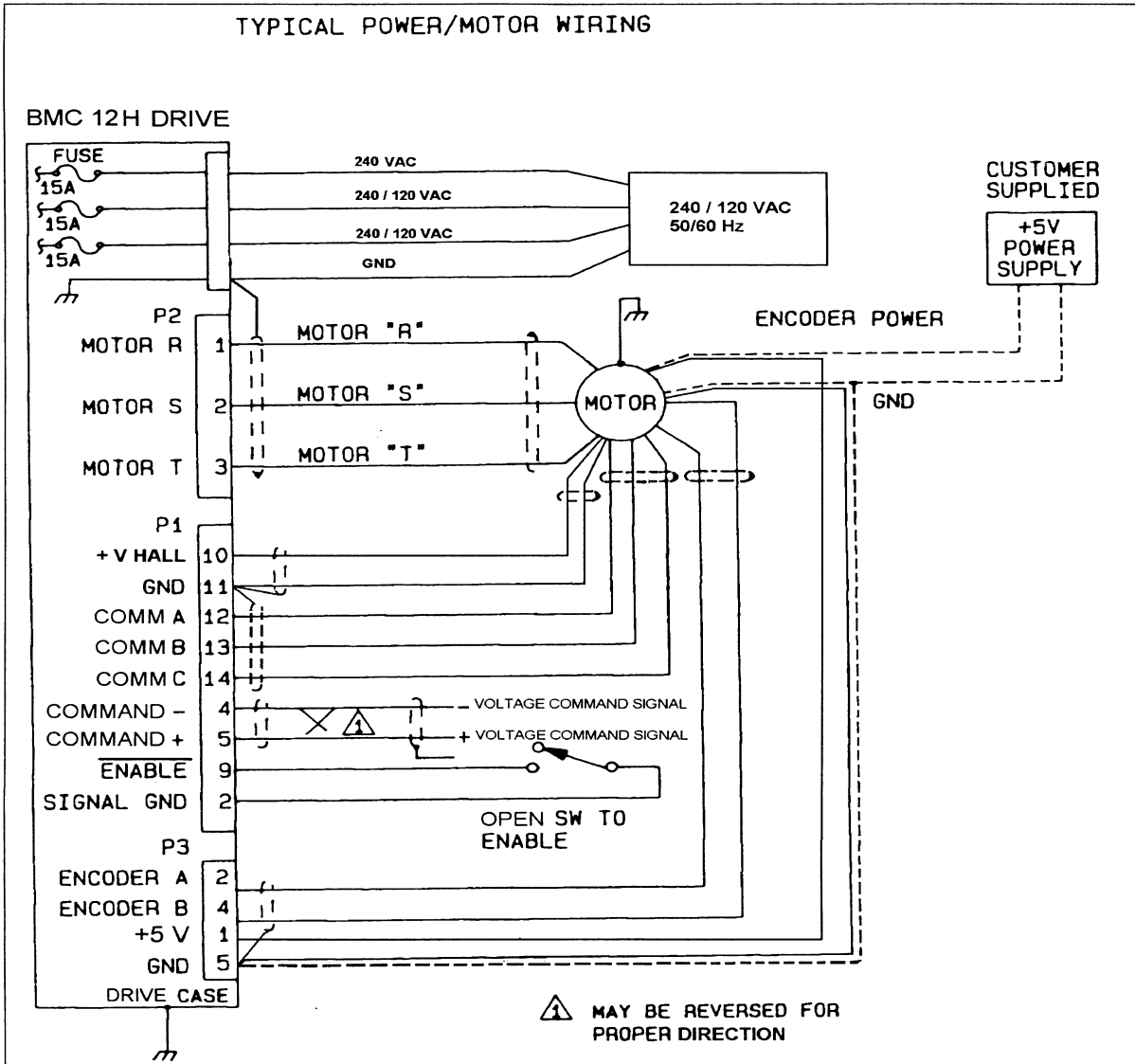

Figure (4) Wiring and Connections Diagram

### 2.7.2 Wiring

Wiring sizes and practices as well as grounding and shielding techniques described in this section represent common wiring practices and should prove satisfactory in the majority of applications.

Due to the switching nature of this PWM drive, care should be exercised in routing power and signal wiring in the system. Noise radiated from nearby electrical or electronic equipment may cause undesired servo motor movement due to pickup by the drive's signal inputs. Likewise, the drive power outputs can generate noise which could be picked up by the drive's signal inputs or by other electronic equipment located near the controller's output wiring.

To reduce the possibility of noise pickup, power and signal lines should be twisted, shielded and routed separately. Ideally the power signal lines should run in separate conduits or be paced at least 12" apart.

**Warning**

*The user is responsible for conforming to all applicable local, national and international codes. Wiring practices, grounding disconnects and over current protection are of particular importance. Nonstandard applications, special operating conditions, and system configurations may differ from what's described in this section.*

**Note**

*The grounding connections for the AC power, chassis, and motor must be connected as shown in the interface connection diagram.*

Refer to Appendix B for more information

### 2.7.3 P2 - Motor Wiring

Twisted, shielded pair wiring for motor cabling is recommended. Ground the shield end only at the drive end as shown in figure (4). The motor power inputs are connected to the drive output.

Cable requirements: Use #14 to #16 AWG for cabling. Obtain twisted wire cable. If the cable used is shielded, connect the shield to the drive end only; refer to figure (4) "Wiring and Connections Diagram."

**NOTES**

1. **DO NOT** use wire shield to carry motor current.
2. **DO NOT** solder or pre-tin the tips of the cable going into the screw terminal connector, solder will contract and will result in loose connections over time.

***MCG offers pre-made cables for easier connectivity with its Automation Line Duty (AB series) brushless line servomotors.***

Refer to Appendix A, B and C for more information

## 2.7.4 P1 - Signal Connector

This is a 16 pin Molex type I/O (input and output) connector. The Molex mating connector part numbers are:

Molex Plastic Body 22-01-3167  
 Insert Terminals 08-50-0114

The standard crimping hand tool is:

Molex part number 11-01-0185

The following table shows the pin assignment and the functionality along with a brief description of each pin.

P1 pin NO.	Function	Function / Description
1	+10 Vdc @ 5 mAmp	<ul style="list-style-type: none"> <li>For customer use.</li> <li>Internal AC-DC converter which generates the internal +/- 12 Vdc from the high DC power supply input, and also outputs regulated voltages of +/- 10 Vdc @ 5 mA.</li> <li>These are short circuit protected.</li> </ul>
2	Signal GND	
3	-10 Vdc @ 5 mAmp	
4	COMMAND -	<ul style="list-style-type: none"> <li>Analog command signal, a differential type signal to drive the servo drive.</li> <li>In velocity mode, the differential COMMAND signal is the velocity command.</li> <li>In torque (current) mode, the differential COMMAND signal is the torque or current command.</li> <li>Separate scale and offset adjustments are used in conjunction with this input.</li> <li>Input impedance of 50 kΩ.</li> <li>Maximum input voltage +/- 15 Volts.</li> </ul>
5	COMMAND +	
6	- TACH IN	<ul style="list-style-type: none"> <li>The negative tachometer input.</li> <li>Maximum input impedance 60 kΩ.</li> <li>Maximum input voltage +/- 60 Volts.</li> </ul>
7	VEL MONITOR OUT	<ul style="list-style-type: none"> <li>Velocity monitor output.</li> <li>1 V = 25 kHz encoder pulse frequency.</li> <li>1 V = 100 Hz hall velocity mode.</li> </ul>
8	CURRENT MONITOR	<ul style="list-style-type: none"> <li>This output signal is proportional to the actual current in the motor leads.</li> <li>Scaling is 2 Amps / 1 Volt when SW3 is OFF.</li> <li>Scaling is 4 Amps / 1 Volt when SW3 is ON.</li> </ul>
9	ENABLE	<ul style="list-style-type: none"> <li>The servo drive will be disabled if this pin is pulled to ground (pin 2 SIGNAL GND).</li> <li>To reverse this functionality (pulling this pin to ground, pin 2 SIGNAL GND will enable the drive), simply remove J1 (a black color surface mount component with three zeros written on it and surrounded by a white box) from the inside the unit.</li> </ul>

10	+V Hall	<ul style="list-style-type: none"> <li>+5V output @ 30 mA, short circuit protected. Power for the Hall sensors.</li> </ul>
11	GND	
12	COMM A	<ul style="list-style-type: none"> <li>The commutator channel inputs (Halls).</li> <li>Logic levels, internal 2 kΩ pull-ups.</li> <li>Maximum low-level input is 1.5 V.</li> <li>Minimum high level input is 3.5 V.</li> </ul>
13	COMM B	
14	COMM C	
15	CURRENT REF OUT	<ul style="list-style-type: none"> <li>Monitors the input signal connected directly to the internal current amplifier.</li> <li>Scaled to 7.5 Vdc = 25 Amps.</li> </ul>
16	FAULT OUTPUT	<ul style="list-style-type: none"> <li>Under no fault condition this output is low.</li> <li>Under a fault condition this output is high.</li> <li>Faults are output short circuit, over voltage, over temperature, disable and during power on reset.</li> <li>Fault condition indicated by red LED.</li> </ul> <p style="text-align: center;"><b><u>Note</u></b></p> <p>Fault conditions are <b><u>NOT LATCHED</u></b>. When a fault condition is removed, the drive will be enabled and can resume motion if commanded.</p>

P1 Signal Interface Connector

**For the internal circuit representations of the above connection points, refer to figure (1) “Functional Block Diagram.”**

### 2.7.5 COMM (hall sensors) Wiring

Twisted 22 AWG shielded cable is the minimum requirement for COMM (hall sensor) cabling. Ground the shield at the drive end only; refer to figure (4), “Wiring and Connections Diagram.”

Refer to Appendix B for more information.

### 2.7.6 COMMAND Signal Wiring

- Twisted, shielded pair wire for the COMMAND input signal is recommended. Connect the shield to the command signal source and not to the drive.
- If the command signal source is ungrounded, connect the shield to both the source and the drive ground.
- It is recommended that the input be connected directly to the drive differential input.
- If the signal command source and the drive are grounded to the master chassis ground, leave the source end of the shield unconnected. The drive-input circuit will attenuate the common mode voltage between the signal command source and the drive power grounds.
- If the direction of motor rotation is not the desired one, reverse the polarity on the COMMAND input or interchange COMM A & COMM C; then motor leads R & S.**

**Refer to figure (4), and appendix B for more information.**

### 2.7.7 P2 - Motor Connections

P2 is a 3-pin screw terminal connector, which connects the drive to the motor phases.

P2 Pin NO	Signal	Description
1	MOTOR PHASE R	R phase power to motor.
2	MOTOR PHASE S	S phase power to motor.
3	MOTOR PHASE T	T phase power to motor.

P2 Motor Interface Connection

Cable requirements: Use #14 to #16 AWG for cabling, twisted.

*MCG supplies pre-made cables for the Automation Duty Brushless Line servomotors.*

#### **NOTES**

1. **DO NOT** solder or pre-tin the tips of the cable going into the screw terminal connector, solder will contract and will result in loose connections over time.
2. **DO NOT** use wire shield to carry power current and voltage.

Refer to Appendix A, B and C for more information

### 2.7.8 P3 - Encoder Connector

This is a 5 pin Molex type I/O (input and output) connector. The Molex mating connector part numbers are:

Molex Plastic Body 22-01-3057  
 Insert Terminals 08-50-0114

The standard crimping hand tool is:

Molex part number 11-01-0185

The following table shows the pin assignment and the functionality along with a brief description of each pin.

P3 pin NO.	Function	Function / Description
1	+5 Vdc	<ul style="list-style-type: none"> <li>Encoder power (output).</li> <li>Rated current 500 mA.</li> </ul>
2	CHANNEL A	<ul style="list-style-type: none"> <li>The Encoder input (quadrature).</li> <li>Maximum input voltage 5 Volts (CMOS).</li> </ul>
3	NC	<ul style="list-style-type: none"> <li>Not Connected</li> <li>There should be no connections made to this pin.</li> </ul>
4	CHANNEL B	<ul style="list-style-type: none"> <li>The Encoder input (quadrature).</li> <li>Maximum input voltage 5 Volts (CMOS).</li> </ul>
5	GND	<ul style="list-style-type: none"> <li>Reference ground for the encoder signals.</li> <li>Connect the +5 Vdc <b><u>return</u></b> (common of the power supply) to this point.</li> </ul>

P3 Encoder Signals Interface Connector

### 2.7.8.1 Encoder Wiring

Twisted 22 AWG shielded pair cable is the minimum requirement for encoder cabling. Ground the shield at the drive end only; refer to figure (4) “Wiring and Connections Diagram.”

**There are two ways for proper electrical connection:**

**If the +5 Vdc is available from the customer controller**

1. **Connect all encoder signals from the motor to the controller**
2. **Connect encoder power to the controller**
3. **Connect the GND from the controller to the GND pin on the BMC12H (P3-5)**
4. **Refer to the connection diagram on page 8, figure 4 (use the dotted connections)**
5. **Refer to section 3 for the proper mode selections and connections**

**If the +5 Vdc is NOT available from the customer controller**

1. **Connect all encoder signals from the motor to the controller**
2. **Connect encoder power to the BMC12H (P3-1 & P3-5)**
3. **Connect the GND from the controller to the GND pin on the BMC12H (P3-5)**
4. **Refer to the connection diagram on page 8, figure 4 (use the solid connections)**
5. **Refer to section 3 for the proper mode selections and connections**

**The MCG encoders require 5 Vdc @ 150 mA).**

**It is very important to tie the common of the power supply to P3-5.**

Refer figure 4 and to Appendix B for more information

### 3.0 Operating / Configuration Mode Selection

The drive can be configured into 5 different operating modes via a DIP switch. These modes are:

- Torque (current) Mode.
- Hall Velocity Mode.
- Encoder Velocity Mode.
- Open Loop Mode.
- Tachometer Velocity Mode.

#### 3.1 Switch Functions

Switch	Function / Description	Setting	
		ON	OFF
1	Offset / Test. Defines the function of Pot. 4	Onboard reference signal in test mode.	Offset adjustment when OFF.
2	Current Loop Gain	Decrease	Increase
3	Current Scaling	100 %	50 % ( $I_{peak}$ & $I_{cont}$ are reduced by 50 %)
4	Loop Integrator. This capacitor normally ensures “error free” operation by reducing the error signal (output of summing amplifier) to zero	<ul style="list-style-type: none"> <li>• Shorts (disables) the loop integrator capacitor (velocity/voltage)</li> <li>• <b><u>It is recommended to set it ON in Torque (current) mode</u></b></li> </ul>	<ul style="list-style-type: none"> <li>• Integrator operating (velocity/voltage)</li> <li>• <b><u>It is recommended to set it OFF in Velocity or Open Loop modes.</u></b></li> </ul>
5	Duty cycle feedback	For Open Loop - ON	For Open Loop - NO effect (OFF)
6	Velocity Feedback	Connects the internally generated velocity signal from encoder	Does not connect the internally generated velocity signal from encoder
7	Velocity Direction	Changes the polarity of the velocity feedback signal	Changes the polarity of the velocity feedback signal
8	Continuous current reduction. Reduces continuous current limit by 50 %	Continuous / Peak current limit ratio is 50 %	Continuous / Peak current limit ratio is 25 %
9	Integrator capacitor. Adjusts the value of the integrator capacitor in velocity mode	Increases the value	Decreases the value
10	60 / 120 degree commutation phasing setting	120 degree, All MCG brushless DC motors are 120 degree commutator (Hall) phasing	60 degree

DIP switch Functionality

### 3.1.1 Current Loop Integrator, SW2, R26 and C69

The current loop response (bandwidth) is determined by the current loop gain resistor, refer to figure (1) “Functional Block Diagram.” SW2, R26 and C69 control the PI (proportional and integral) gains of the current loop.

Current loop response is inversely proportional to motor inductance. Higher inductance motors require higher proportional gain to obtain the same response as lower inductance motors.

The greater the resistor value the faster the response. If the resistor value is too high for the inductance, overshoot or oscillation occurs in the current loop.

Typically the standard drive settings:

- 10 k $\Omega$  is recommended for load inductor less than 2 mH.
- 100 k $\Omega$  setting is recommended for more than 2 mH.

This may be accomplished by switching on the extra capacitor with the DIP switch SW2 or by installing a through-hole resistor in R26. For load inductors higher than 5 mH, a 200 m $\Omega$  or higher resistance can be placed in R26 for faster response. If the resistor value is too high for the inductance, overshoot or isolation occurs in the current loop.

**In most applications, leaving SW2 in the OFF position is recommended.** By doing so the signal is being integrated and the error signal is being reduced as well as the amount of signal overshoot. If the gain resistor value has been changed, C69 has to change.

Since adjustments of these components can cause possible damage to the drive’s power section, extreme care should be exercised if changing these components. Consult your local MCG distributor before attempting to change or add components.

### 3.1.2 Velocity Loop Integrator, SW4, SW9, C67

The velocity loop integrator capacitor can be used to compensate for large load inertia. The greater the load inertia the greater the capacitor value is required. This can be done by switching SW4 OFF and switching SW9 ON at the same time or by installing a larger through hole capacitor (C67), and leaving SW4 and SW9 OFF; refer to figure (1) “Functional Block Diagram.”

Shorting out the velocity integrator capacitor by turning SW4 ON and SW9 OFF can verify the need for a larger capacitor. If the velocity loop is stable with the capacitor shorted out and unstable with the capacitor in the circuit, then a greater capacitor value is needed.

If the capacitor is included in the circuit (SW4 OFF), it will force the motor velocity to precisely follow the commanded velocity (reducing the velocity error), this assuming steady state operation where the velocity command or the load DOES NOT change.

The velocity loop integrator along with POT1 “LOOP GAIN” controls the stiffness and the ability to reject load torque disturbance. Too high of a capacitor value could cause an overshoot in the velocity loop and may cause the system to become unstable or break into oscillations.

The velocity loop response (bandwidth) is determined by POT 1 (LOOP GAIN). The greater the POT value (the more turns from CCW), the faster the response.

### 3.2 Potentiometer Functions

Potentiometer	Function	Description	Turning CW
Pot 1	Loop Gain	<ul style="list-style-type: none"> <li>Loop gain adjustments in voltage and velocity modes.</li> <li>Voltage to current scaling factor adjustment in current mode.</li> <li>It is also a function of SW4, SW9 &amp; C67.</li> <li>If in <b><u>TORQUE (CURRENT) MODE</u></b> setting, this potentiometer should be set <b><u>FULLY CCW</u></b>, otherwise a runaway condition may occur.</li> </ul>	Increases loop gain
Pot 2	Current Limit	<ul style="list-style-type: none"> <li>Adjusts both continuous and peak current limit by maintaining a ratio of 2:1 (peak: continuous).</li> <li>It is also a function of SW3 &amp; SW8.</li> </ul>	Increases current limit
Pot 3	Command Gain	<ul style="list-style-type: none"> <li>Adjusts the ratio between the input COMMAND signal and the output variables (voltage, current, and velocity).</li> <li>Turn this POT CW until the required output is obtained for a given input COMMAND signal.</li> <li>If in <b><u>TORQUE (CURRENT) MODE</u></b> setting, this potentiometer should be set <b><u>FULLY CW</u></b>.</li> </ul>	Increases COMMAND input gain
Pot 4	Test / Offset	<ul style="list-style-type: none"> <li>When SW1 is OFF. This pot is used to adjust any imbalance in the input signal or in the drive.</li> <li>When SW1 is ON, the sensitivity of this pot is greatly increased; so it can be used as an onboard signal source for test purposes.</li> </ul>	NA

#### Potentiometer Functionality

##### 3.2.1 LOOP GAIN (POT 1) ADJUSTMENT

The velocity loop response (bandwidth) is determined by POT 1, “LOOP GAIN.” The greater the POT value (the more turns from CCW), the faster the response.

POT1 “LOOP GAIN,” along with the velocity loop integrator (SW4, SW9 and C67), control the stiffness and the ability to reject load torque disturbance. Increasing resistance (turning POT 1 CW) causes an overshoot in the velocity loop and may cause the system to be unstable or break into oscillations.

**NOTE**

*If in **TORQUE (CURRENT) MODE** setting, this potentiometer should be set **FULLY CCW**, otherwise a runaway condition may occur.*

### 3.2.2 CURRENT LIMIT, “POT 2” ADJUSTMENT

It is critical to set the current limit so that the instantaneous motor current does not exceed the specified motor peak current ratings. Should this occur, the motor may be demagnetized. This would reduce both the torque constant and the torque rating of the motor and seriously affect the system performance.

MCG servo drives feature peak and continuous current limit adjustments. The maximum peak current is needed for fast acceleration and deceleration. This drive is capable of supplying the maximum peak current for 2 seconds and then the current limit is reduced gradually to the continuous value.

The purpose of this is to protect the motor in stalled condition by reducing the current limit to the maximum continuous value. Current limiting is done in the drive by reducing the output voltage to the motor.

The current limit adjustment potentiometer, “POT 2,” has one inactive turn at each end and is approximately linear. Thus, to adjust the current limit, turn POT 2 CCW to zero then turn it CW to the appropriate setting.

Use the following table for approximated current settings:

Number of turns from Fully CCW	SW3 OFF SW8 OFF		SW3 OFF SW8 ON		SW3 ON SW8 ON		SW3 ON SW8 OFF	
	I <sub>Cont</sub>	I <sub>Peak</sub>	I <sub>Cont</sub>	I <sub>Peak</sub>	I <sub>Cont</sub>	I <sub>Peak</sub>	I <sub>Cont</sub>	I <sub>Peak</sub>
5	±1.0	±4.17	±2.1	±4.2	±4.2	±8.4	±2.1	±8.4
10	±2.1	±8.4	±4.2	±8.4	±8.3	±16.7	±4.2	±16.8
15	±3.125	±12.5	±6.25	±12.5	±12.5	±25	±6.25	±25

Since the output current is proportional to P1-15 “CURRENT REFERENCE,” the adjusted current limit can be easily observed at this pin. The maximum peak current value equals 7.5 V at this pin with respect to P1-2, “SIGNAL GROUND.”

The actual current can be monitored at pin P1-8, “CURRENT MONITOR,” with respect to P1-2, “SIGNAL GROUND.” This output signal is proportional to the actual current in the motor leads and is scaled as follows:

Scaling is 2 Amps / 1 Volt when SW3 is OFF.  
Scaling is 4 Amps / 1 Volt when SW3 is ON.

If the peak current reference does not reach the set peak current limit, the time for the peak current will be longer than 2 seconds. The actual time is a function of the RMS current.

### 3.3 Torque (current) Mode

The torque (current) mode produces a torque output from the motor proportional to the COMMAND voltage input signal. The brushless DC servo motor output torque is proportional to the motor current.

Torque (current) mode is especially important if the servo drive is used with a digital position controller. Under this condition, a movement of the motor shaft from the desired position causes a large correcting torque or “stiffness.” Therefore, this mode may produce a “runaway” condition if operated without a controller.

#### 3.3.1 Torque (current) Mode Setup Procedure

**Note**

*The following setup procedure should be done with the motor unloaded (the load is uncoupled from the motor shaft)*

1. Set the DIP switch to following settings:

SW1	SW2	SW3	SW4	SW5	SW6	SW7	SW8	SW9	SW10	ENC	TACH
OFF	OFF	ON	ON	OFF	OFF	ON	ON	ON	ON	NC	NC

2. Set the potentiometer to the following settings:

Pot 1	Pot 2	Pot 3	Pot 4
Loop Gain	Current Limit	Command Gain	Test / Offset
Fully CCW	3 Turns from Fully CCW (initial setup)	Fully CW	Factory Settings

3. Ensure the ENABLE input is inactive (P1-9 connected to P1-2).
4. Connect COMM A, B & C (hall) sensors to P1 pins 12, 13 & 14 respectively
5. Connect the Motor leads R, S & T to P2 pins 1, 2 & 3 respectively.
6. ***Encoder & Tachometer do not have to be connected to the drive in torque (current) mode.***
7. Check the AC voltage source before connecting it to the drive and make sure that it is within the 70 - 270 Vdc limits **OR** that the DC bus voltage (1.414 \* AC input voltage) does not exceed the motor’s maximum terminal voltage.
8. Connect the AC power to the drive, **DO NOT APPLY POWER YET.**
9. Check the unit wiring per figure (4) “Wiring and Connection Diagram.”
10. Ensure that the COMMAND (P1-12, 13) input voltage signals are ZERO.
11. Apply power to the drive; verify that the LED is RED.
12. ENABLE the drive. The LED should turn GREEN by now. *The motor may rotate at this point. Be prepared to disable the controller or remove the AC power if excessive motion occurs.* If the motor rotates, adjust POT 4 until the motor stops rotating.
13. Command a small torque (current) through the COMMAND input voltage signal.

14. The motor should rotate in a smooth manner. If the motor rotates in the opposite direction of that desired for a given COMMAND input polarity, check the connection on the motor leads and the COMM or the polarity connection to the COMMAND input.
15. **If the direction of motor rotation is not the desired one, reverse the polarity on the COMMAND input or interchange COMM A & COMM C; then motor leads R & S.**
16. Adjust POT 2, "CURRENT LIMIT," to the motor maximum continuous current rating or to the desired maximum torque for the application. Use the following potentiometer approximation settings:

Number of turns from Fully CCW	SW3 OFF SW8 OFF		SW3 OFF SW8 ON		SW3 ON SW8 ON		SW3 ON SW8 OFF	
	I <sub>Cont</sub>	I <sub>Peak</sub>	I <sub>Cont</sub>	I <sub>Peak</sub>	I <sub>Cont</sub>	I <sub>Peak</sub>	I <sub>Cont</sub>	I <sub>Peak</sub>
5	±1.0	±4.17	±2.1	±4.2	±4.2	±8.4	±2.1	±8.4
10	±2.1	±8.4	±4.2	±8.4	±8.3	±16.7	±4.2	±16.8
15	±3.125	±12.5	±6.25	±12.5	±12.5	±25	±6.25	±25

17. It is recommended to set POT 3 fully CW in this mode.

### 3.4 Hall Velocity Mode

The frequency of the hall signals is proportional to motor speed. The BMC 12H internal circuitry decodes velocity information. This analog signal is available for closed loop velocity control. The DIP switch according to the following table can select Hall velocity mode. Since the resolution of the hall signals is not very high, this mode does not provide good velocity control at low speeds (fewer than 300 RPM).

The optimal response can be achieved by adjusting the “LOOP GAIN,” POT 1. Increase it by turning CW until the motor breaks into oscillation, then turn it back slightly until the motor stops oscillating. Changing the velocity loop integrator value SW9 may improve the response.

The polarity of velocity signal should be the same as the polarity of the input signal. For positive input signals the velocity monitor should be positive. SW7 can be used to set the correct polarity.

Note the speed is dependent on terminal voltage and motor current. The motor current is in turn dependent on the load torque, which includes both constant friction torque and the torque to accelerate or decelerate the load. In general, compensation of velocity feedback system is more complex than that of open loop mode.

#### 3.4.1 Hall Velocity Mode Setup Procedure

**NOTE**

*The following setup procedure should be done with the motor unloaded (the load is uncoupled from the motor shaft).*

1. Set the DIP switch to following settings:

SW1	SW2	SW3	SW4	SW5	SW6	SW7	SW8	SW9	SW10	ENC	TACH
OFF	OFF	ON	OFF	OFF	ON	ON	ON	ON	ON	NC	NC

2. Set the potentiometer to the following settings:

Pot 1	Pot 2	Pot 3	Pot 4
Loop Gain	Current Limit	Command Gain	Test / Offset
Fully CCW	3 Turns from Fully CCW (initial setup)	Fully CCW	Factory Settings

3. Ensure the ENABLE input is inactive (P1-9 connected to P1-2).
4. Connect COMM A, B & C (hall) sensors to P1 pins 12, 13 & 14 respectively.
5. Connect the Motor leads R, S & T to P2 pins 1, 2 & 3 respectively.
6. Check the AC voltage source before connecting it to the drive and make sure that it is within the 70 - 270 Vdc limits **OR** that the DC bus voltage (1.414 \* AC input voltage) does not exceed the motor maximum voltage terminal.
7. Connect the AC power to the drive, (DO NOT APPLY POWER YET).

8. Check the unit wiring per figure (4) “Wiring and Connection Diagram.”
9. Ensure that the COMMAND (P1-12, 13) input voltage signals are ZERO.
10. Apply power to the drive and verify that the LED is RED.
11. ENABLE the drive. The LED should be GREEN by now. *The motor may rotate at this point. Be prepared to disable the controller or remove the AC power if excessive motion occurs.* If the motor rotates, adjust POT 4 until the motor stops rotating.
12. Command a small velocity command through the COMMAND input voltage signal.
13. The motor should rotate in a smooth manner. If motor rotates in the opposite direction of that desired for a given COMMAND input polarity, check the connection on the motor leads and the COMM or the polarity connection to the COMMAND input.
14. **If the direction of motor rotation is not the desired one, reverse the polarity on the COMMAND input or interchange COMM A & COMM C; then motor leads R & S.**
15. Adjust POT 2, “CURRENT LIMIT,” to the motor maximum continuous current rating or to the desired maximum torque for the application. Use the following potentiometer approximation settings:

Number of turns from Fully CCW	SW3 OFF SW8 OFF		SW3 OFF SW8 ON		SW3 ON SW8 ON		SW3 ON SW8 OFF	
	I <sub>Cont</sub>	I <sub>Peak</sub>	I <sub>Cont</sub>	I <sub>Peak</sub>	I <sub>Cont</sub>	I <sub>Peak</sub>	I <sub>Cont</sub>	I <sub>Peak</sub>
5	±1.0	±4.17	±2.1	±4.2	±4.2	±8.4	±2.1	±8.4
10	±2.1	±8.4	±4.2	±8.4	±8.3	±16.7	±4.2	±16.8
15	±3.125	±12.5	±6.25	±12.5	±12.5	±25	±6.25	±25

16. While the motor is stationary (not rotating by commanding zero volts through the COMMAND input, P1-4 and P1-5), begin turning POT 1 CW until the motor begins to oscillate. Once the motor begins to oscillate, turn POT 1 until the motor stops oscillating. Refer to sections 3.1.2 & 3.2.1 (“Velocity Loop Integrator” & Loop Gain POT 1) of this manual.
17. Adjust POT 3, “COMMAND GAIN,” to the desired scaling of the command-input voltage. If the maximum input COMMAND voltage is 10 V and the drive/motor maximum speed is 1000 rpm, then for 1 volt COMMAND input, the drive should command 100 rpm at the motor shaft. If the drive is not commanding 100 rpm, then you may adjust POT 3, “COMMAND GAIN,” until you reach 100 rpm per 1 volt applied. The commanded motor speed can be measured by using a hand held tach or by using the following equations

$$\text{Hall sensor cycle / mechanical revolution} = \text{Poles} / 2$$

$$\text{Motor RPM} = \text{Hall sensor frequency (Hz)} * 60 / (\text{poles} / 2).$$

Or

$$\text{Motor RPM} = \text{Velocity monitor [V]} * \text{Scale Factor (Hz/V)} * 60 / (\text{Pole} / 2)$$

**Note: 1 Volt = 100 Hz (velocity monitor scaling).**

### 3.5 Encoder Velocity Mode

With this addition, the frequency of the encoder signal is proportional to motor speed. The BMC 12H internal circuitry decodes velocity information. This analog signal is available for closed loop velocity control. The DIP switch according to the following table can select encoder velocity mode.

The optimal response can be achieved by adjusting the “LOOP GAIN,” POT1. Increase it by turning CW until the motor breaks into oscillation, then turn it back slightly until the motor stops oscillating. Changing the velocity loop integrator value SW9 may improve the response.

**The polarity of velocity signal should be the same as the polarity of the input signal. For positive input signals, the velocity monitor should be positive. SW7 can be used to set the correct polarity.**

Note that the speed is dependent upon terminal voltage and motor current. The motor current is in turn dependent on the load torque, which includes both constant friction torque and the torque to accelerate or decelerate the load. In general, compensation of the velocity feedback system is more complex than that of open loop mode, this operating mode also results in the best performance.

**NOTE:**

***If an external +5 Vdc power supply is needed to power the encoder, refer to the connections diagram for wiring or section 2.7.8.1 Encoder Wiring.***

#### 3.5.1 Encoder Velocity Mode Setup Procedure

**NOTE**

*The following setup procedure should be done with the motor unloaded (the load is uncoupled from the motor shaft).*

1. Set the DIP switch to following settings:

SW1	SW2	SW3	SW4	SW5	SW6	SW7	SW8	SW9	SW10	ENC	TACH
OFF	OFF	ON	OFF	OFF	OFF	ON	ON	ON	ON	CON	NC

2. Set the potentiometer to the following settings:

Pot 1	Pot 2	Pot 3	Pot 4
Loop Gain	Current Limit	Command Gain	Test / Offset
Fully CCW	3 Turns from Fully CCW (initial setup)	Fully CCW	Factory Settings

3. Ensure that the ENABLE input is inactive (P1-9 connected to P1-2).
4. Connect COMM A, B & C (hall) sensors to P1 pins 12, 13 & 14 respectively.
5. Connect the Motor leads R, S & T to P2 pins 1, 2 & 3 respectively.
6. ***Encoder must be connected to the drive in this mode. If an external +5 Vdc power supply is needed to power the encoder, refer to the connections diagram for wiring or section 2.7.8.1 Encoder Wiring.***

7. Check the AC voltage source before connecting it to the drive and make sure that it is within the 70 - 270 Vdc limits **OR** that the DC bus voltage (1.414 \* AC input voltage) does not exceed the motor maximum voltage terminal.
8. Connect the AC power to the drive (DO NOT APPLY POWER YET).
9. Check the unit wiring per figure (4), “Wiring and Connection Diagram.”
10. Ensure that the COMMAND (P1-12, 13) input voltage signal is ZERO.
11. Apply power to the drive and verify that the LED is RED.
12. ENABLE the drive. The LED should be GREEN by now. *The motor may rotate at this point. Be prepared to disable the controller or remove the AC power if excessive motion occurs.* If the motor runs away, set SW7 in the opposite setting of what you set before and if the motor rotates, adjust POT 4 until the motor stops rotating.
13. Command a small velocity command through the COMMAND input voltage signal.
14. The motor should rotate in a smooth manner. If motor rotates in the opposite direction of that desired for a given COMMAND input polarity, check the connection on the motor leads and the COMM or the polarity connection to the COMMAND input.
15. **If the direction of motor rotation is not the desired one, reverse the polarity on the COMMAND input or interchange COMM A & COMM C; then motor leads R & S.** You should also reverse the connection of the encoder channels A and B or simply set SW7 to the OFF position to avoid run-away conditions.
16. Adjust POT 2, “CURRENT LIMIT,” to the motor maximum continuous current rating or to the desired maximum torque for the application. Use the following potentiometer approximation settings:

Number of turns from Fully CCW	SW3 OFF SW8 OFF		SW3 OFF SW8 ON		SW3 ON SW8 ON		SW3 ON SW8 OFF	
	I <sub>Cont</sub>	I <sub>Peak</sub>	I <sub>Cont</sub>	I <sub>Peak</sub>	I <sub>Cont</sub>	I <sub>Peak</sub>	I <sub>Cont</sub>	I <sub>Peak</sub>
5	±1.0	±4.17	±2.1	±4.2	±4.2	±8.4	±2.1	±8.4
10	±2.1	±8.4	±4.2	±8.4	±8.3	±16.7	±4.2	±16.8
15	±3.125	±12.5	±6.25	±12.5	±12.5	±25	±6.25	±25

17. While the motor is stationary (not rotating, by commanding zero volts through the COMMAND input, P1-4 and P1-5), begin turning POT 1 CW until the motor begins to oscillate. Once the motor begins to oscillate, turn POT 1 until the motor stops oscillating. Refer to sections 3.1.2 & 3.2.1 (“Velocity Loop Integrator” & Loop Gain POT 1) of this manual.
18. Adjust POT 3, “COMMAND GAIN,” to the desired scaling of the command input voltage. If the maximum input COMMAND voltage is 10 V and the drive/motor maximum speed is 1000 rpm, then for 1 volt COMMAND input, the drive should command 100 rpm at the motor shaft. If the drive is not commanding 100 rpm, then you may adjust POT 3, “COMMAND GAIN,” until you reach 100 rpm per 1 volt applied. The commanded motor speed can be measured either by using a hand held tach or by measuring the velocity monitor voltage. Place a voltmeter across P1-7 & P1-2 and use the following equation to estimate the motor speed in RPM:  
***Velocity Monitor (V) \* Scale factor (25KHz / V) \* 60 / (4 \* Encoder line count).***

***Note: 1 Vdc = 25 kHz encoder frequency on the velocity monitor output.***

## 3.6 Open Loop Mode

In the open mode, the COMMAND input signal commands a proportional motor voltage (by changing the duty cycle of the output switching). This mode is open loop configuration (unlike other modes described); therefore the average output voltage is also a function of the power supply voltage.

### 3.6.1 Open Loop Mode Setup Procedure

#### **NOTE**

*The following setup procedure should be done with the motor unloaded (the load is uncoupled from the motor shaft).*

1. Set the DIP switch to following settings:

SW1	SW2	SW3	SW4	SW5	SW6	SW7	SW8	SW9	SW10	ENC	TACH
OFF	OFF	ON	OFF	ON	OFF	ON	ON	ON	ON	NC	NC

2. Set the potentiometer to the following settings:

Pot 1	Pot 2	Pot 3	Pot 4
Loop Gain	Current Limit	Command Gain	Test / Offset
Fully CCW	3 Turns from Fully CCW (initial setup)	Fully CCW	Factory Settings

3. Ensure that the ENABLE input is inactive (P1-9 connected to P1-2).
4. Connect COMM A, B & C (hall) sensors to P1 pins 12, 13 & 14 respectively
5. Connect the Motor leads R, S & T to P2 pins 1, 2 & 3 respectively.
6. ***Encoder & Tachometer do not have to be connected to the drive in open mode.***
7. Check the AC voltage source before connecting it to the drive and make sure that it is within 70 - 270 Vdc maximum **OR** that the DC bus voltage ( $1.414 * \text{AC input voltage}$ ) does not exceed the motor's maximum terminal voltage.
8. Connect the AC power to the drive (DO NOT APPLY POWER YET).
9. Check the unit wiring per figure (4) "Wiring and Connection Diagram."
10. Ensure that the COMMAND (P1-12, 13) input voltage signal is ZERO.
11. Apply power to the drive and verify that the LED is RED.
12. ENABLE the drive. The LED should be GREEN by now. *The motor may rotate at this point. Be prepared to disable the controller or remove the AC power if excessive motion occurs.* If the motor rotates, adjust POT 4 until the motor stops rotating.
13. Command a small torque (current) through the COMMAND input voltage signal.
14. The motor should rotate in a smooth manner. If motor rotates in the opposite direction of that desired for a given COMMAND input polarity, check the connection on the motor leads and the COMM or the polarity connection to the COMMAND input.
15. **If the direction of motor rotation is not the desired one, reverse the polarity on the COMMAND input or interchange COMM A & COMM C; then motor leads R & S.**

16. Adjust POT 2, the CURRENT LIMIT, to the motor maximum continuous current rating or to the desired maximum torque for the application.
17. Use the following potentiometer approximation settings:

Number of turns from Fully CCW	SW3 OFF SW8 OFF		SW3 OFF SW8 ON		SW3 ON SW8 ON		SW3 ON SW8 OFF	
	I <sub>Cont</sub>	I <sub>Peak</sub>	I <sub>Cont</sub>	I <sub>Peak</sub>	I <sub>Cont</sub>	I <sub>Peak</sub>	I <sub>Cont</sub>	I <sub>Peak</sub>
5	±1.0	±4.17	±2.1	±4.2	±4.2	±8.4	±2.1	±8.4
10	±2.1	±8.4	±4.2	±8.4	±8.3	±16.7	±4.2	±16.8
15	±3.125	±12.5	±6.25	±12.5	±12.5	±25	±6.25	±25

18. While the motor is stationary (not rotating, by commanding zero volts through the COMMAND input, P1-4 and P1-5), begin turning POT 1 CW until the motor begins to oscillate. Once the motor begins to oscillate, turn POT 1 until the motor stops oscillating. Refer to sections 3.1.2 & 3.2.1 (“Velocity Loop Integrator” & Loop Gain POT 1) of this manual.
19. Adjust POT 3, the COMMAND GAIN, to the desired scaling of the command-input voltage. If the maximum input COMMAND voltage is 10 V, and the drive/motor maximum speed is 1000 rpm, then for 1 volt COMMAND input, the drive should command 100 rpm at the motor shaft. If the drive is not commanding 100 rpm, then you may adjust POT 3 “COMMAND GAIN” until you reach 100 rpm per 1 volt applied. The commanded motor speed can be measured either by using a hand held tach or by using the following equation to estimate the motor speed in RPM:

### 3.7 Tachometer Velocity Mode

The addition of a DC tachometer to the motor shaft produces a voltage proportional to speed. With this addition, the tachometer output voltage replaces the motor terminal voltage as the controlled variable. Since this voltage is proportional to the motor speed, the operating mode is velocity mode.

This analog signal is available for closed loop velocity control. The DIP switch according to the following table can select tachometer velocity mode.

The optimal response can be achieved by adjusting the “LOOP GAIN,” POT 1. Increase it by turning POT 1 CW until the motor breaks into oscillation, then turn it back slightly until the motor stops oscillating. Changing the velocity loop integrator value SW9 may improve the response.

Note that the speed is dependent upon terminal voltage and motor current. The motor current is in turn dependent upon the load torque, which includes both constant friction torque and the torque required to accelerate or decelerate the load. In general, compensation of velocity feedback system is more complex than that of open loop mode. This operating mode also results in better performance compared to open loop mode.

#### 3.7.1 Tachometer Velocity Mode Setup Procedure

**NOTE**

*The following setup procedure should be done with the motor unloaded (the load is uncoupled from the motor shaft).*

1. Set the DIP switch to following settings:

SW1	SW2	SW3	SW4	SW5	SW6	SW7	SW8	SW9	SW10	ENC	TACH
OFF	OFF	ON	OFF	OFF	OFF	ON	ON	ON	ON	NC	CON

2. Set the potentiometer to the following settings:

Pot 1	Pot 2	Pot 3	Pot 4
Loop Gain	Current Limit	Command Gain	Test / Offset
Fully CCW	3 Turns from Fully CCW (initial setup)	Fully CCW	Factory Settings

3. Ensure the ENABLE input is inactive (P1-9 connected to P1-2).
4. Connect COMM A, B & C (hall) sensors to P1 pins 12, 13 & 14 respectively
5. Connect the Motor leads R, S & T to P2 pins 1, 2 & 3 respectively.
6. ***Tachometer has to be connected to the drive in this mode. P1 pin 6 & 11, Tach- and Tach+ respectively.***
7. Check the AC voltage source before connecting it to the drive and make sure that it is within 90 - 270 Vac maximum **OR** that the DC bus voltage (1.414 \* AC input voltage) does not exceed the motor maximum voltage terminal.

8. Connect the AC power to the drive (DO NOT APPLY POWER YET).
9. Check the unit wiring per figure (4) “Wiring and Connection Diagram.”
10. Ensure that the COMMAND (P1-12, 13) input voltage signal is ZERO.
11. Apply power to the drive. Verify that the LED is RED.
12. ENABLE the drive. The LED should be GREEN by now. *The motor may rotate at this point. Be prepared to disable the controller or remove the AC power if excessive motion occurs.* If the motor rotates, adjust POT 4 until the motor stops rotating.
13. Command a small velocity command through the COMMAND input voltage signal.
14. The motor should rotate in a smooth manner. If the motor rotates in the opposite direction of that desired for a given COMMAND input polarity, check the connection on the motor leads and the COMM or the polarity connection to the COMMAND input.
15. **If the direction of motor rotation is not the desired one, reverse the polarity on the COMMAND input or interchange COMM A & COMM C; then motor leads R & S.** You should also reverse the TACH connections to avoid run-away conditions.
16. Adjust POT 2, “CURRENT LIMIT,” to the motor maximum continuous current rating or to the desired maximum torque for the application. Use the following potentiometer approximation settings:

Number of turns from Fully CCW	SW3 OFF SW8 OFF		SW3 OFF SW8 ON		SW3 ON SW8 ON		SW3 ON SW8 OFF	
	I <sub>Cont</sub>	I <sub>Peak</sub>	I <sub>Cont</sub>	I <sub>Peak</sub>	I <sub>Cont</sub>	I <sub>Peak</sub>	I <sub>Cont</sub>	I <sub>Peak</sub>
5	±1.0	±4.17	±2.1	±4.2	±4.2	±8.4	±2.1	±8.4
10	±2.1	±8.4	±4.2	±8.4	±8.3	±16.7	±4.2	±16.8
15	±3.125	±12.5	±6.25	±12.5	±12.5	±25	±6.25	±25

17. While the motor is stationary (not rotating, by commanding zero volts through the COMMAND input, P1-4 and P1-5), begin turning POT 1 CW until the motor begins to oscillate. Once the motor begins to oscillate turn POT 1 until the motor stops oscillating. Refer to sections 3.1.2 & 3.2.1 (“Velocity Loop Integrator” & Loop Gain POT 1) of this manual.
18. Adjust POT 3, “COMMAND GAIN,” to the desired scaling of the command input voltage. If the maximum input COMMAND voltage is 10 V and the drive/motor maximum speed is 1000 rpm, then for 1 volt COMMAND input, the drive should command 100 rpm at the motor shaft. If the drive is not commanding 100 rpm, then you may adjust POT 3, “COMMAND GAIN,” until you reach 100 rpm per 1 volt applied. The commanded motor speed can be measured either by using a hand held tach or by measuring the TACH voltage. If the TACH gradient is 14 V/KRPM then for 100 RPM (motor speed) and 1 Vdc input the TACH voltage should be 1.4 V dc.

## 4.0 Maintenance and Troubleshooting

- Normally the only maintenance required is to remove the dust and dirt from the drive, use low-pressure air less than 15 psi.
- Drive status is indicated by the single LED located above the P2 connector.
- The Drive faults are indicated by the red LED.
- Faults are also indicated by the FAULT output on P1-16; the output will be high if the drive detects any fault.
- There are no field serviceable components in the drive.
- It is recommended that in the event of a drive failure the entire drive is replaced and the defective drive returned to the factory for repair.
- Verify the drive is defective before replacing or returning for repair.

The following table, is a troubleshooting guide to diagnose and correct most problems. Follow the steps in section 4.1 to determine the functionality of the drive. If you are unable to achieve satisfactory operation contact your local MCG distributor.

### **IMPORTANT NOTE**

*If you suspect that the servo drive has been damaged, **DO NOT** simply replace it with another servo drive and apply power. Recheck your AC power supply, motor and connections and verify that they meet all requirements.*

Problem or Symptom	Possible Cause	Action / Solution
LED not lit	NO AC power	<ul style="list-style-type: none"> <li>• Verify AC power is applied to drive (70 - 270 Vac).</li> <li>• Check for open circuit breakers.</li> </ul>
	Blown Fuses	<ul style="list-style-type: none"> <li>• Check fuses.</li> <li>• Check for short circuits.</li> </ul>
Green LED, but no motor response	Wiring	<ul style="list-style-type: none"> <li>• Open motor and feedback connections.</li> <li>• COMMAND not reaching P1-4, P1-5.</li> <li>• COMMAND is ZERO (or shorted).</li> </ul>
	Electrical	<ul style="list-style-type: none"> <li>• CURRENT LIMIT pot is turned fully CCW.</li> <li>• COMMAND GAIN pot is turned fully CCW.</li> <li>• LOOP GAIN pot is turned fully CCW.</li> <li>• Under voltage, verify power supply is within minimum condition.</li> </ul>
	Mechanical	<ul style="list-style-type: none"> <li>• Seized load.</li> <li>• Excessive frictional load.</li> <li>• Verify motor shaft turns freely with no power.</li> </ul>
Motor causes erratic operation	Loop Gain Pot set too high	<ul style="list-style-type: none"> <li>• If the drive is in velocity mode, turn Loop Gain pot CCW until oscillation stops.</li> <li>• Controller gains are too high.</li> </ul>
	Noise	<ul style="list-style-type: none"> <li>• Improper grounding, check the drive/system grounding (drive signal ground is not connected to source signal ground).</li> <li>• Noisy command signal.</li> <li>• Excessive feedback noise.</li> </ul>

	Mechanical	<ul style="list-style-type: none"> <li>• Mechanical backlash, select a larger reduction ratio so the reflected inertia is equal to motor inertia.</li> <li>• Slippage.</li> </ul>
	Electrical	<ul style="list-style-type: none"> <li>• Excessive voltage spikes on the AC (DC) power input.</li> </ul>
	Feedback	<ul style="list-style-type: none"> <li>• User supplied position and/or velocity loop is improperly compensated.</li> </ul>
System runaway	Wiring	<ul style="list-style-type: none"> <li>• If in velocity mode setting, check the polarity and wiring connection for: <ul style="list-style-type: none"> <li>The motor leads.</li> <li>The halls.</li> <li>The encoder.</li> <li>The tach.</li> </ul> Check the connection on the P3-5 and P3-1 to the encoder power and GND.  Set SW7 in the opposite setting of what you have.  Check and reset the DIP switch settings </li> <li>• If in torque (current) mode, check that POT 1, “Loop Gain,” is set fully CCW.</li> </ul>
	Feedback	<ul style="list-style-type: none"> <li>• User supplied position or velocity loop has failed.</li> <li>• Check the feedback polarity and wiring (reverse Enc A and Enc B wiring) or the TACH polarity.</li> </ul>
RED LED is lit	Drive disabled	<ul style="list-style-type: none"> <li>• Check connection on P1-9. Enable the drive by opening the connection on P1-9 and P1-2 <u>or</u> P1-11.</li> <li>• Check SW1-10 setting for the proper HALL phasing.</li> <li>• Check the HALL supplies voltage (P1-10 and P1-11).</li> <li>• Check the current loading on P1-1 and P1-3 by removing the connections on these pins.</li> </ul>
	Over temperature	<ul style="list-style-type: none"> <li>• Excessive ambient temperature.</li> <li>• Heatsink temperature above 65 degrees C.</li> <li>• Restriction of cooling air due to insufficient spacing around the drive.</li> <li>• Add a fan or improve air circulation.</li> <li>• Drive is being operated above its continuous power rating.</li> <li>• Change your motion profile.</li> </ul>
	Output short circuit	<ul style="list-style-type: none"> <li>• Check each motor lead for shorts with respect to motor housing and power ground.</li> <li>• Measure motor armature resistance between motor leads with the drive disconnected for shorts.</li> <li>• Insufficient motor inductance.</li> </ul>
	Over voltage	<ul style="list-style-type: none"> <li>• Check the input voltage, maximum input voltage is 270 Vac.</li> <li>• Check the DC line connected to the power source for proper input value.</li> <li>• Check the regenerative energy absorbed during deceleration. This is done with a voltmeter or scope and monitoring the DC power supply voltage. If the supply voltage increases above 420 volts, change your motion profile (deceleration).</li> </ul>
	Over Current	<ul style="list-style-type: none"> <li>• Insufficient motor inductance.</li> <li>• Seized load or Excessive frictional load</li> <li>• Verify motor shaft turns freely with no power.</li> <li>• Change motion profile.</li> <li>• The system gains are too high.</li> </ul>

## 4.1 Testing the BMC 12H Brushless Servo Drive

The BMC 12H is designed to perform a self-test using POT 4, the OFFSET / TEST potentiometer to control an onboard signal source. This test can be used to confirm that the servo drive is functional. The test requires an AC power source (70 - 270 Vac), a multimeter and a DC brushless servo motor.

1. Take note of the DIP switch settings before starting the test.
2. Always be prepared to turn the main power OFF.
3. Refer to figure (2) “Wiring and Connection Diagram.”
4. Set the DIP switch on the servo drive to the following settings “positions”:

SW1	SW2	SW3	SW4	SW5	SW6	SW7	SW8	SW9	SW10	ENC	TACH
ON	OFF	ON	OFF	ON	OFF	ON	ON	ON	ON	NC	NC

5. Set the “CURRENT LIMIT” POT 2 to the motor specifications, use the following table for the approximated current settings:

Number of turns from Fully CCW	SW3 OFF SW8 OFF		SW3 OFF SW8 ON		SW3 ON SW8 ON		SW3 ON SW8 OFF	
	I <sub>Cont</sub>	I <sub>Peak</sub>	I <sub>Cont</sub>	I <sub>Peak</sub>	I <sub>Cont</sub>	I <sub>Peak</sub>	I <sub>Cont</sub>	I <sub>Peak</sub>
5	±1.0	±4.17	±2.1	±4.2	±4.2	±8.4	±2.1	±8.4
10	±2.1	±8.4	±4.2	±8.4	±8.3	±16.7	±4.2	±16.8
15	±3.125	±12.5	±6.25	±12.5	±12.5	±25	±6.25	±25

6. Connect COMM A, B and C (hall) sensors to P1 pins 12, 13 and 14.
7. Connect the COMM power leads to P1-10, and COMM GND to P1-11.
8. **DO NOT CONNECT THE MOTOR LEADS (PHASES R, S AND T) YET.**
9. Apply power, by turning the AC power source ON.
10. Check that the LED is GREEN (normal operation).
11. Turn the motor shaft manually one revolution; the LED should remain GREEN. If the LED is RED or changes color:
  - Check 60/120 degree phase switch setting (SW10, MCG setting is ON)
  - Check power to for COMM (hall) sensors
  - Check voltage levels for the COMM (hall) input
12. Turn the AC power source OFF and wait 10 seconds.
13. Connect the motor leads, phases R, S and T to P2 pins 1, 2 and 3 respectively.
14. Turn the AC source power ON.
15. Check that the LED is GREEN.
16. Verify smooth operation by turning the “TEST/OFFSET” potentiometer, POT 4, fully CW then fully CCW, motor should run smooth and reverse in both directions.
17. Set POT4, “TEST/OFFSET,” such that it will bring the motor to stop rotating.
18. Turn the AC power source OFF.
19. Set the DIP switch settings to the original factory settings or to your suitable mode.

If the drive failed the above test proceed to the next section. And if the drive passed the above test start checking your system and wiring by the isolation method.

## 4.2 Defective Equipment

If you are unable to correct the problem and the drive is defective, you may return the drive to your local MCG distributor for repair or replacement. There are no field serviceable parts in the drive.

### **NOTE**

**To save unnecessary work and repair charges please write a note and attach to the defective drive explaining the problem.**

## 4.3 Return Procedure

To ensure accurate processing and prompt return of any MCG products, the following procedure must be followed:

1. Call your local MCG distributor to obtain an RMA number.
2. Do not return any goods without an RMA number.
3. Goods received without an RMA number will **NOT** be accepted and will be returned to sender.
4. Pack the returned goods in the original shipping carton.
5. MCG is **NOT** responsible or liable for damage resulting from improper packaging or shipping.
6. Repaired units are shipped via UPS ground delivery. If another shipping method is desired, please indicate so when requesting an RMA number and also indicate this information along with the return goods.

### **NOTE**

***Do not attempt to return the BMC 12H or any other equipment without a valid RMA#. Returns received without a valid RMA# will not be accepted and will be returned to the sender.***

*Pack the drive in its original shipping carton. MCG, Inc. is not responsible or liable for damage resulting from improper packaging shipment.*

*Ship the drive to:*

*MCG Inc.  
1500 North Front Street  
New Ulm, MN 56073 - 0637  
Attn.: Repair Department RMA# \_\_\_\_\_*

## Appendix A: Motor and Drive Selections

Determine voltage and current requirements for the motor, based upon maximum velocity and torque.

Generally motor voltage is proportional to the motor speed and motor current is proportional to motor shaft torque. This relationship is described by the following equations:

$$\begin{aligned}V_b &= K_e * \omega_m \\V_t &= (I_m * R_m) + V_b \\T &= K_t * I_m\end{aligned}$$

where:

$V_b$	= Back EMF voltage	(volts)
$K_e$	= Motor Voltage Constant	(V/KRPM)
$\omega_m$	= Motor Speed	(RPM)
$V_t$	= Terminal voltage (DC power voltage)	(volts)
$I_m$	= Motor current	(amps)
$R_m$	= Motor terminal resistance (winding)	(ohms)
$T$	= Motor load torque	(lb-in or Nm)
$K_t$	= Motor Torque Constant	(lb-in/Amp or Nm/Amp)

*Note: Usually the motor manufacture data sheet will contain the  $K_t$  and  $K_e$  values.*

Determining the motor maximum speed and torque will determine maximum voltage and current.

$$V_{max} = (K_e * \omega_{max}) * 1.10$$

For example, a motor with a  $K_e$  of 10 V/KRPM and required speed of 3000 RPM would require 33 Vdc minimum to operate successively (the IR term was neglected in this calculation).

It is recommended to select a power supply voltage with a 10 % higher than the maximum required for the motor used in the application. This is a safety percentage to account for the variances in the motor  $K_e$ ,  $K_t$  and losses in the system external to the drive.

Maximum current required for your application and from your system (drive/motor) can be calculated as follow:

$$I_{max} = T_{max} / (K_t * .95)$$

For example, a motor with  $K_t = 1$  lb-in/Amp and a maximum torque required of 4 lb-in would require a minimum of 4.2 Amps. The term ( $K_t * .95$ ) is called the effective  $K_t$  (effective torque constant) of the motor which assumes a hot value for the application.

## **Appendix B: General Wiring Tips**

### Noise and System Grounding Considerations

Noise - can be coupled:

- Capacitively (electrostatic coupling) onto the signal wires in the circuit (the effect is more serious for high impedance points).
- Magnetically to closed loops in the signal circuit (independent of impedance levels).
- Electromagnetically to signal wires acting as small antennas for electromagnetic radiation.
- From one part of the circuit to other parts through voltage drops on ground lines.

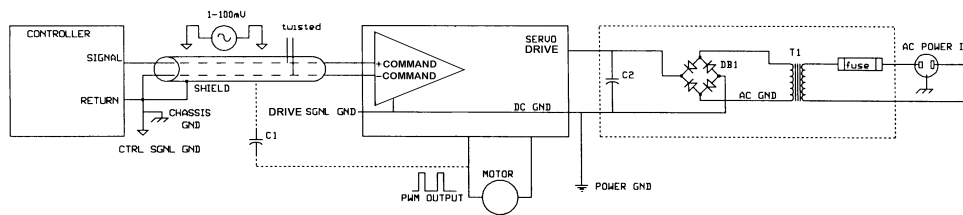

Figure (B-1) Typical Wiring Diagram for Noise Consideration and System Grounding.

Experience shows that the main source of noise is the high  $dV/dT$  (typically 1V/nanosecond) of the drive's output power MOSFETs. The PWM output can be coupled back to the signal lines through straight capacitance "C1" between output and input wires. The best methods are to reduce capacitance between the offending points (move signal and motor leads apart), add shielding and use differential inputs at the drive.

Unfortunately, low frequency magnetic fields are not significantly reduced by metal enclosures. Typical sources are 50 or 60 Hz power transformers and low frequency current changes in the motor leads. The best solution in this case is to avoid large loop areas in signal, power supply and motor wires. Twisted pairs of wires are quite effective in reducing magnetic pick up because the enclosed area is small, and the signals induced in successive twist cancel. Aside from overall shielding the best way to reduce radio frequency coupling is to keep leads short.

The voltage source between the drive and the controller grounds typically consist of some 60 Hz voltage, harmonics of the line frequency, some radio frequency signals, IR drops and other "ground noise." The differential COMMAND inputs of the drive will ignore the small amount of "ground signal."

Long signal wires (10 - 15 ft and up ) can also be sources of noise when driven from a typical OP AMP output. Due to the inductance and capacitance of the wire, the OP AMP output can oscillate. It is always recommended to set a fixed voltage at the controller and

then check the signal at the drive with an oscilloscope to make sure that the signal is “clean.”

Servo system wiring typically involves wiring the controller (digital or analog), servo drive, power supply and motor. Wiring this servo system components is fairly easy when a few rules are observed.

1. Use shielded, twisted pair wire for the COMMAND input signal and tie the shield at the controller end.
2. It is recommended that the signal, motor, tach, and power wire be routed in separate cable harnesses.
3. All grounds are connected to a single chassis ground, normally the same as earth ground.
4. The grounding design is ultimately the responsibility of the system designer.

## Appendix C: Regenerative Operation and Considerations

During braking (when the motor and load are decelerated by the drive or a downward vertical move), the drive returns the motor's kinetic energy to the power supply capacitor and can charge it to potentially dangerous voltages.

In this case, the motor becomes a generator converting the kinetic energy stored in the spinning motor and load inertias into electrical energy. If this kinetic energy is less than the losses in the drive and motor, the supply voltage does not increase. If the mechanical energy is greater than the losses, the supply voltage will increase.

Consequently, power supplies should have sufficient capacitance to absorb this energy without over charging the drive or the power supply.

The mechanical energy of a spinning inertia can be calculated as follow:

$$E = 3.87 * 10 * J * \omega$$

Where:

E = Kinetic energy	(joules)
J = Inertia	(oz-in-sec <sup>2</sup> )
W = Motor speed	(RPM)

If all or part of this energy is converted to electrical energy in the form of charge on the bus capacitor, the final voltage will be:

$$V = \sqrt{V_o^2 + \frac{2E}{C}}$$

Where:

V = Final voltage	(volts)
V <sub>o</sub> = Initial voltage	(volts)
C = Total capacitance	(farads)
E = Initial kinetic energy	(joules)

The BMC 12H is equipped with a built in shunt regulator circuit. During braking, the DC bus capacitor will charged up to higher voltage. If this higher voltage reaches the BMC 12H over voltage shut down point, output current and braking will cease. To ensure smooth braking for large inertial loads, a shunt circuit is added so it will switch on the shunt resistor when the DC bus reaches 390 Vdc and turns OFF at 380 Vdc. This resistor (20 Ω @ 100 watts) then dissipates the extra energy of the DC bus. The shunt circuit is fused. The time delay 3 amp fuse (MDL 3 @ 250 V) that allows 19.5 amps for 500 msec and it takes the 150 msec for the bus voltage to be at 380 Vdc from 390 Vdc).



*Contact your local distributor or call 1-888-624-3478 (US & Canada)  
for Customer Service & Technical Support  
Internet: [www.mcg-net.com](http://www.mcg-net.com)  
Email: [sales@mcg-net.com](mailto:sales@mcg-net.com)*