



9237S010

Lo-Cog® DC Motor

Assembly Data	Symbol	Units	Value	
Reference Voltage	E	V	24	
No-Load Speed	S _{NL}	rpm (rad/s)	5,331	(558)
Continuous Torque (Max.) ¹	T _C	oz-in (N-m)	11.5	(8.1E-02)
Peak Torque (Stall) ²	T _{PK}	oz-in (N-m)	77	(5.4E-01)
Weight	W _M	oz (g)	16	(439)
Motor Data				
Torque Constant	K _T	oz-in/A (N-m/A)	6.00	(4.24E-02)
Back-EMF Constant	K _E	V/krpm (V/rad/s)	4.44	(4.24E-02)
Resistance	R _T	Ω	1.85	
Inductance	L	mH	1.97	
No-Load Current	I _{NL}	A	0.18	
Peak Current (Stall) ²	I _P	A	13.0	
Motor Constant	K _M	oz-in/√W (N-m/√W)	4.41	(3.11E-02)
Friction Torque	T _F	oz-in (N-m)	0.80	(5.6E-03)
Rotor Inertia	J _M	oz-in-s ² (kg-m ²)	1.2E-03	(8.5E-06)
Electrical Time Constant	τ _E	ms	1.06	
Mechanical Time Constant	τ _M	ms	8.9	
Viscous Damping	D	oz-in/krpm (N-m-s)	0.055	(3.7E-06)
Damping Constant	K _D	oz-in/krpm (N-m-s)	14	(9.7E-04)
Maximum Winding Temperature	θ _{MAX}	°F (°C)	311	(155)
Thermal Impedance	R _{TH}	°F/watt (°C/watt)	52.2	(11.2)
Thermal Time Constant	τ _{TH}	min	13.8	
Gearbox Data				
Encoder Data				

Included Features

- 2-Pole Stator
- Ceramic Magnets
- Heavy-Gauge Steel Housing
- 7-Slot Armature
- Silicon Steel Laminations
- Stainless Steel Shaft
- Copper-Graphite Brushes
- Diamond Turned Commutator
- Motor Ball Bearings

Customization Options

- Alternate Winding
- Sleeve or Ball Bearings
- Modified Output Shaft
- Custom Cable Assembly
- Special Brushes
- EMI/RFI Suppression
- Spur or Planetary Gearbox
- Special Lubricant
- Optional Encoder
- Fail-Safe Brake

1 - Specified at max. winding temperature at 25°C ambient without heat sink. 2 - Theoretical values supplied for reference only.

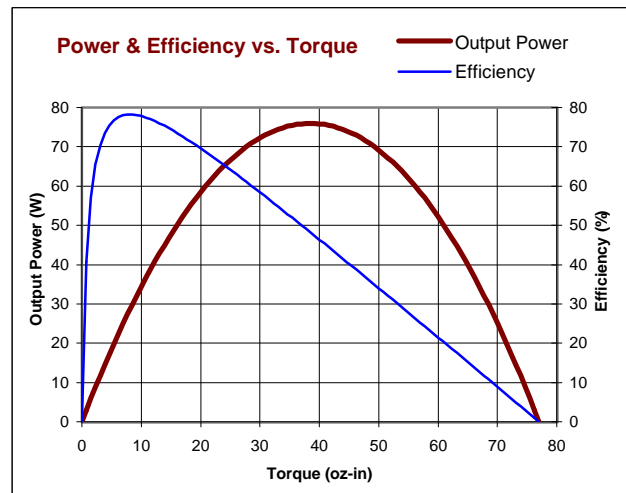
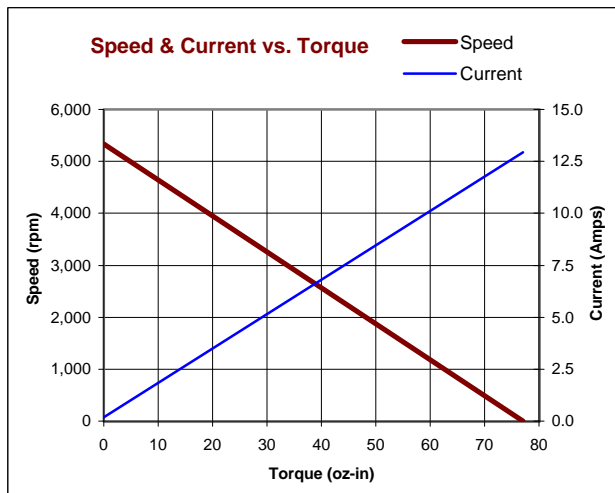

All values are nominal. Specifications subject to change without notice. Graphs are shown for reference only.

© 2001 Pittman.

NOTICE: CONFIDENTIAL PROPRIETARY INFORMATION. THIS PRINT CONTAINS IDEAS, INFORMATION, AND INTELLECTUAL PROPERTY WHICH ARE THE EXCLUSIVE PROPERTY OF PITTMAN, DIVISION OF PENN ENGINEERING & MANUFACTURING CORP. RECIPIENT MUST KEEP THE INFORMATION DISCLOSED HEREIN CONFIDENTIAL AND RECIPIENT IS EXPRESSLY PROHIBITED FROM COPYING OR PUBLICATION OF THIS PRINT EXCEPT TO OTHERS IN THEIR ORGANIZATION ON A NEED-TO-KNOW BASIS.

REVISIONS				
LTR	DESCRIPTION	DRFT/ENGR	DATE	APPR
A	PRODUCTION RELEASE	KUH/KUH	8/13/96	JRM
B	1/4" STRIP & TIN WAS "STRIP"	KUH/KUH		

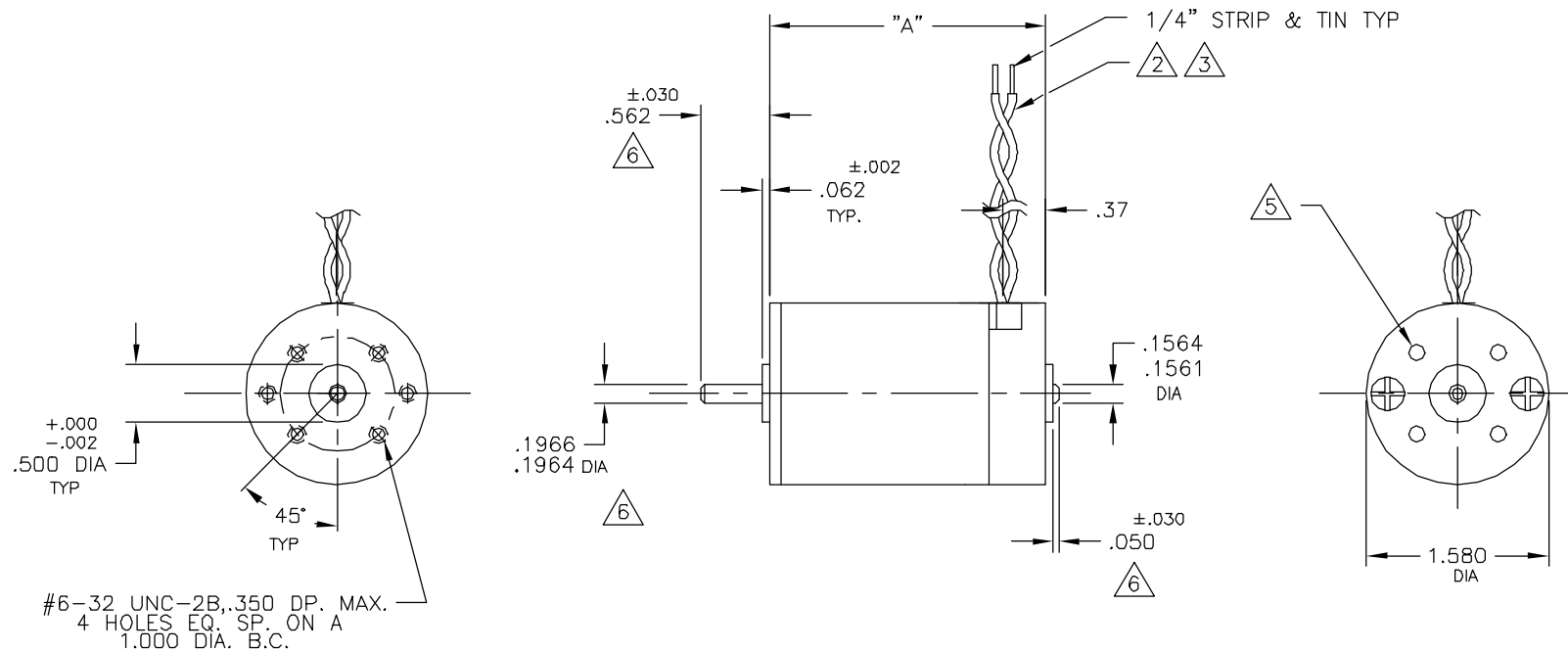

NOTES:

- SHAFT ROTATION IS CW VIEWING MOUNTING END WITH POSITIVE (+) VOLTAGE APPLIED TO RED LEAD.
- LEADS ARE 22 AWG (7X30) PVC INSULATION, UL STYLE 1569/1007. RED AND BLACK
- STANDARD LEAD LENGTH IS $18" \pm 1/2"$
- ENDPLAY-.015 MAX. FOR SLEEVE BEARING MOTORS. BALL BEARING MOTORS ARE PRE-LOADED PER SPEC. P-107
- OPTIONAL REAR ENDBELL MOUNTING PATTERN $\#6-32$ UNC-2B, .180 MAX THREAD PENETRATION, 4 HOLES EQ. SP. ON A 1.000 DIA B.C.
- ALL SHAFT DIMENSIONS NOTED ARE STANDARD (102-004-000): FOR ALL OTHER SHAFT CONFIGURATIONS REFER TO DATA SHEET FOR PART #'S

3.353	92X7
3.053	92X6
2.703	92X5
2.403	92X4
2.203	92X3
1.828	92X2

UNLESS OTHERWISE SPECIFIED DIMENSIONS ARE IN INCHES TOLERANCES ARE: FRACTION DECIMAL ANGLES $\pm 1/64$.X $\pm .015$ $\pm 1^\circ$.XX $\pm .010$.XXX $\pm .005$ BREAK ALL SHARP EDGES	FILE: 150\520	<p>PITTMAN a PennEngineering Company 348 Goddard Drive • Harrisville, PA 16836</p>	DATE 8/12/96	MODEL NO.
	DRAFTED BY KUH		ENGINEERED BY KUH	APPROVED BY JRM
MATERIAL:	NEXT ASSY:	TITLE: OUTLINE AND MTG. DIMS. 92XX SERIES MOTOR-5MM SHAFT		
FINISH:	USED ON:	DWG. NO. B-	150-520	REV. B
		SCALE: NONE	SHEET 1	